

Modesty Screen

FIXED ASSEMBLY INSTRUCTIONS

We all need our own space. Increase office and employee privacy with our selection of modesty screens that attach right onto our desks and benches. In addition, shield cords, wires and more from sight for a clean and organized workspace.

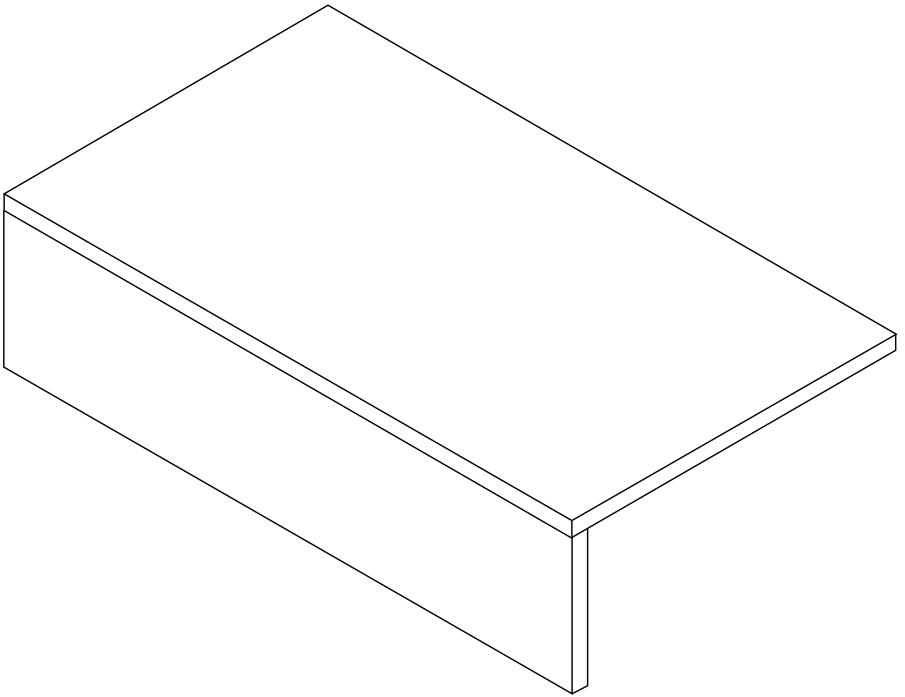

Read the entire instruction manual before you start installation and assembly. If you have any questions regarding any of the instructions or warnings, please contact your local distributor for assistance.

To report any issues with this product, contact our customer experience team at: (888) 274-8664 or sitonit@exemplis.com.

Recommended Tools

- Measuring tape
- Pencil
- #2 Phillips Screwdriver
- Cordless Drill/Driver
- #2 Phillips Bit
- $\frac{3}{32}$ " Drill Bit

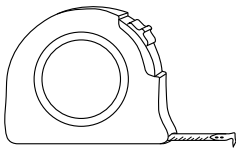

Measuring Tape

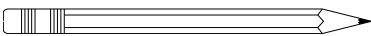

Pencil

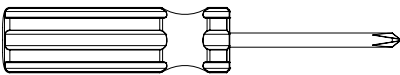

#2 Phillips Screwdriver

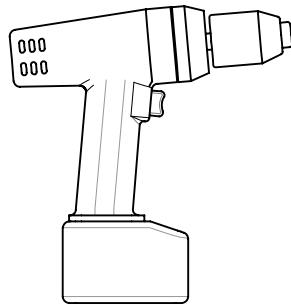

Cordless Drill/Driver

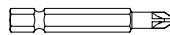

#2 Phillips Bit



$\frac{3}{32}$ " Drill Bit

Parts

Laminate Screens

- Top Bracket (2)
- #10 × ¾" Screw (8)

Acrylic Screens

- Top Bracket (2)
- #10 × ¾" Screw (4)
- #6 Flat Washers (4)
- #6 Hex Nuts (4)
- #6-32 × ¾" Screws (4)
- #6 Split Lock Washers (Discard)

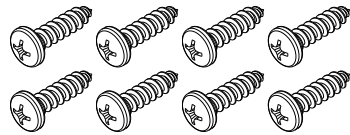
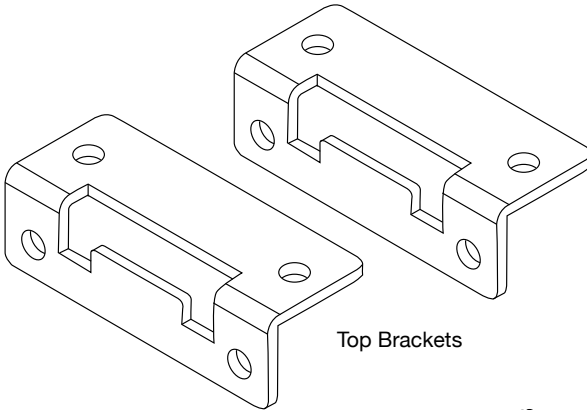

#10 × ¾" Screws

ACRYLIC HARDWARE KIT

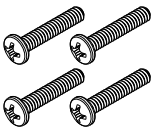

#6-32 × ¾" Screws



#6 Hex Nuts



#6 Flat Washers



#6 Split Lock Washers (Discard)

Step 1: Position the brackets with the tabbed sides flush to the back the screen.

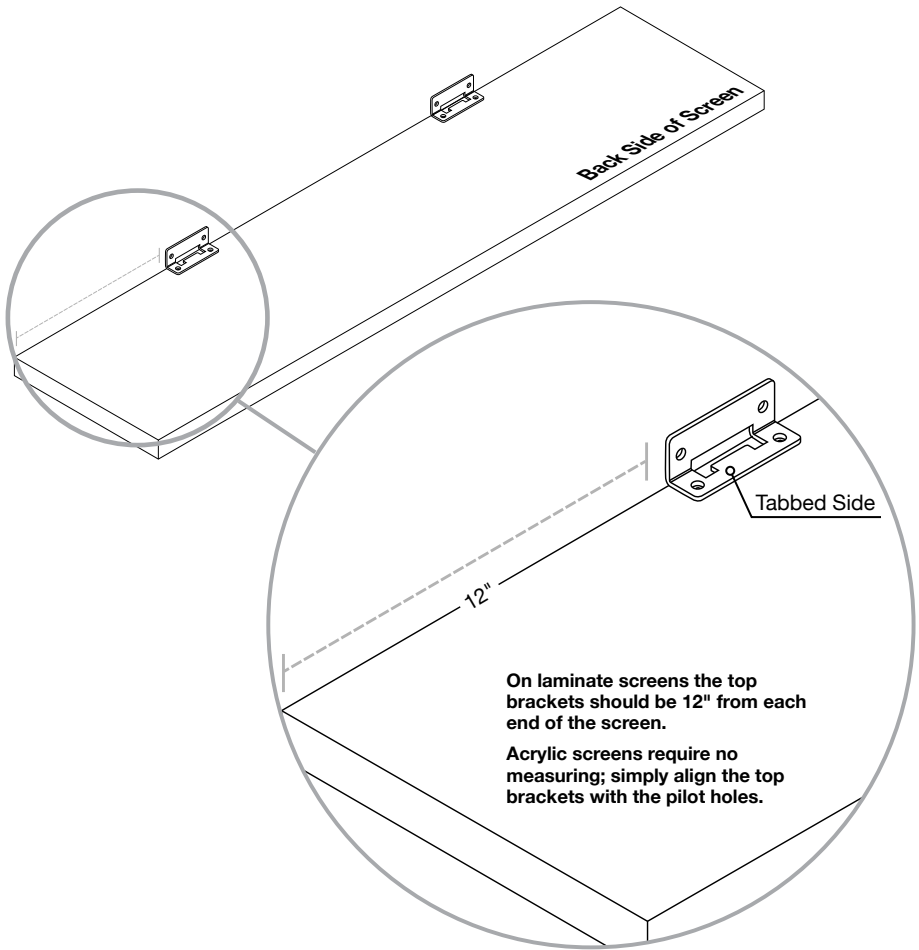

TOOLS

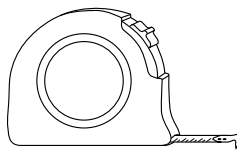

Measuring Tape

Step 2 (Laminate Only): Mark the position of the top brackets and drill $\frac{1}{2}$ " deep pilot holes.

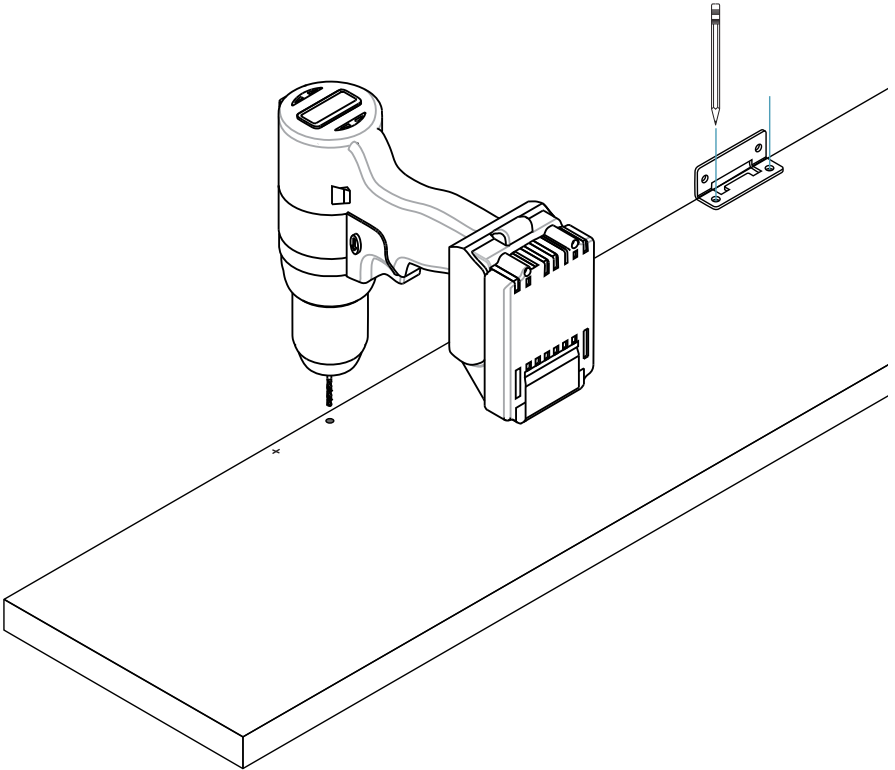

TOOLS

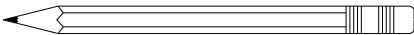

Pencil



$\frac{3}{32}$ " Drill Bit

Step 3 (Laminate): Attach the top brackets to the modesty screen.

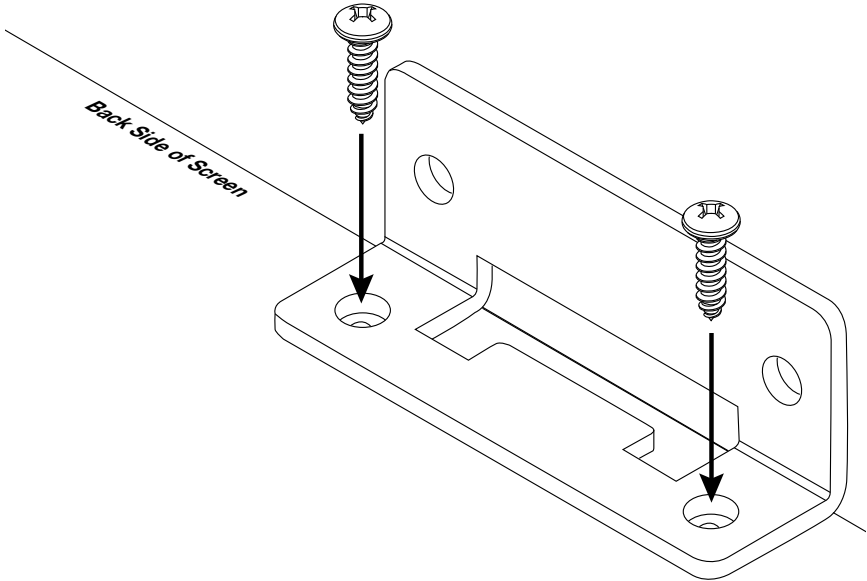

1:1 HARDWARE

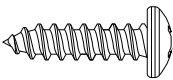

#10 x 3/4" Screw

TOOLS

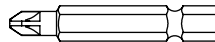

#2 Phillips Bit

Step 3 (Acrylic): Attach the top brackets to the modesty screen.

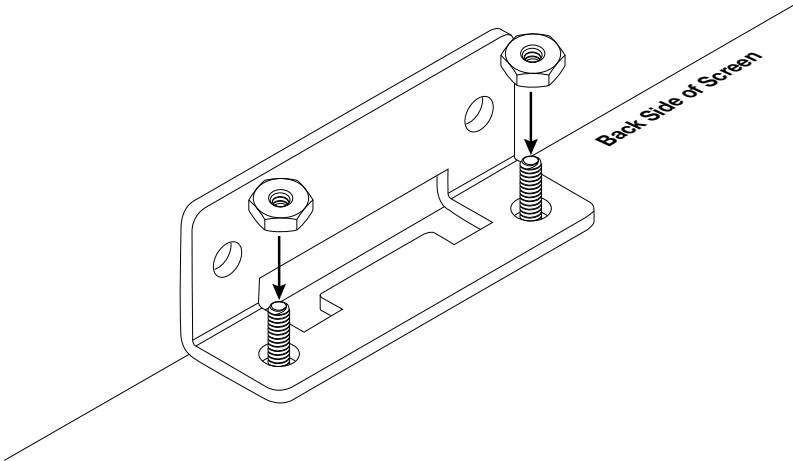
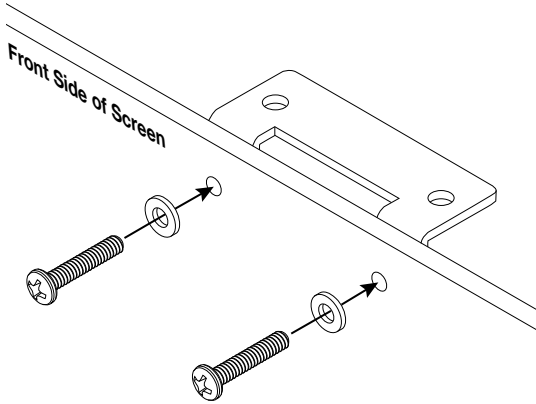

1:1 HARDWARE



#6 Flat Washer



#6-32 × ¾" Screw



#6 Hex Nut

Modesty Screen

FIXED ASSEMBLY INSTRUCTIONS

Step 4: Position the screen over the underside of the tabletop. Mark the position of the top brackets and drill $\frac{1}{2}$ " deep pilot holes.

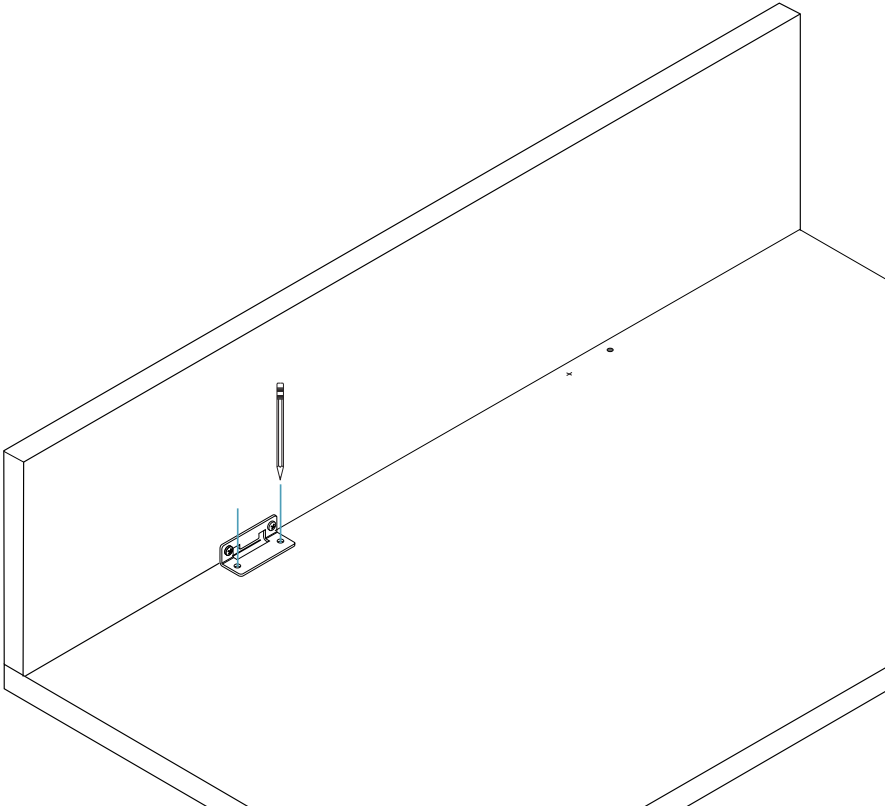

TOOLS

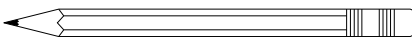

Pencil



$\frac{3}{32}$ " Drill Bit

Step 5: Attach the top brackets to the underside of the tabletop.

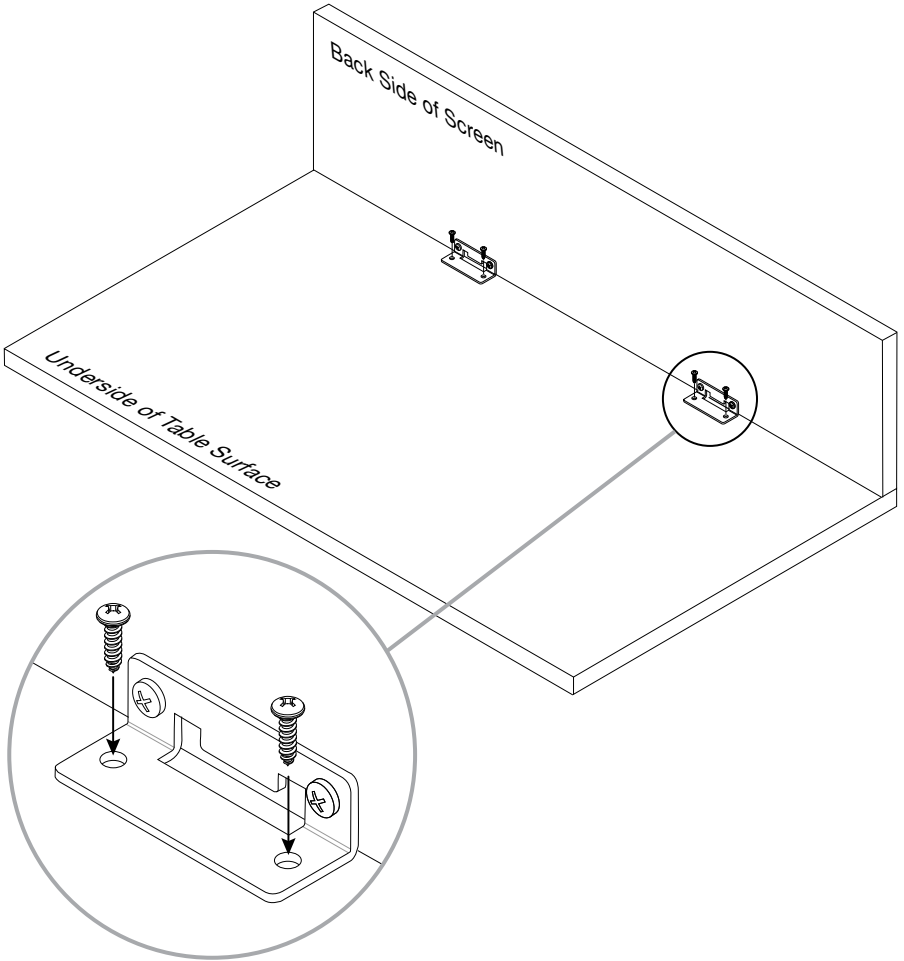

1:1 HARDWARE

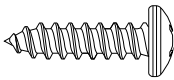

#10 x 3/4" Screw

TOOLS

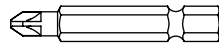

#2 Phillips Bit

Modesty Screen

HINGED ASSEMBLY INSTRUCTIONS

We all need our own space. Increase office and employee privacy with our selection of modesty screens that attach right onto our desks and benches. In addition, shield cords, wires and more from sight for a clean and organized workspace.

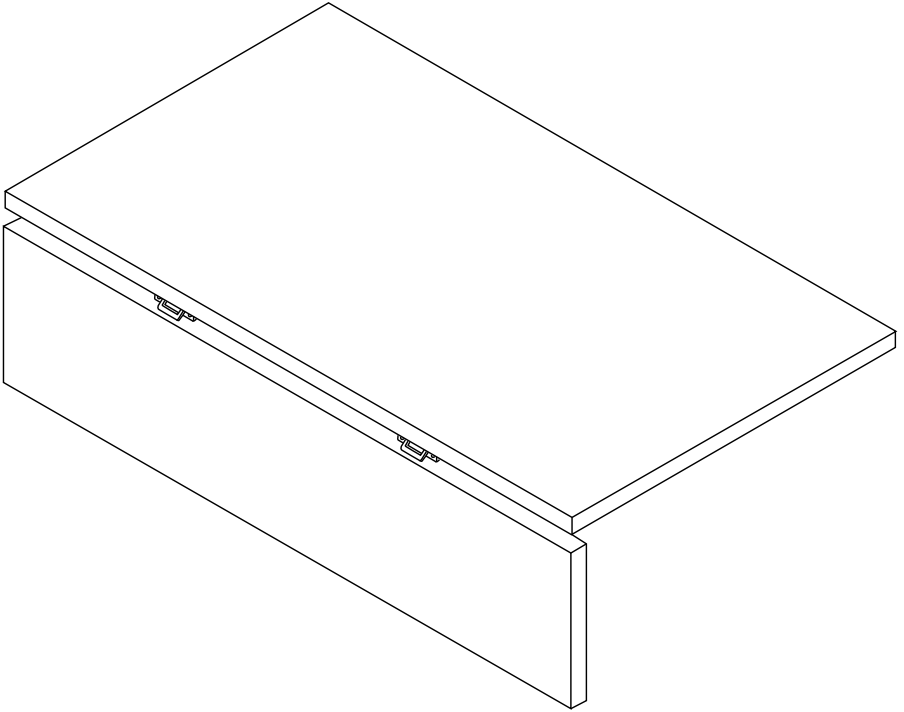

Parts

Laminate Screens

- Top Bracket (2)
- #10 × ¾" Screw (8)

Acrylic Screens

- #6 Flat Washers (4)
- #6 Hex Nuts (4)
- #6-32 × ¾" Screws (4)
- #6 Split Lock Washers (Discard)

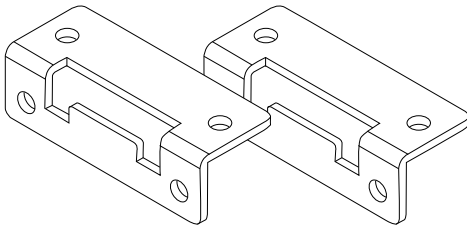

Top Brackets

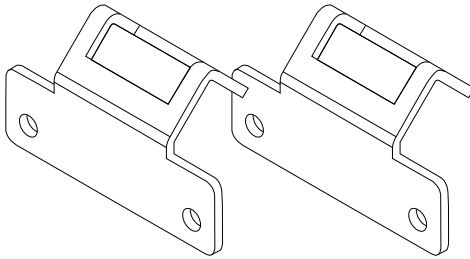

Bottom Brackets

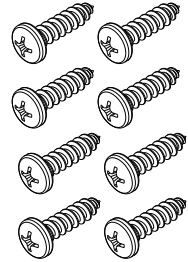

#10 × ¾"

ACRYLIC HARDWARE KIT

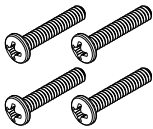

#6-32 × ¾" Screws



#6 Hex Nuts



#6 Flat Washers



#6 Split Lock Washers (Discard)

Step 1: Position the bottom brackets so that they're flush with the back of the screen.

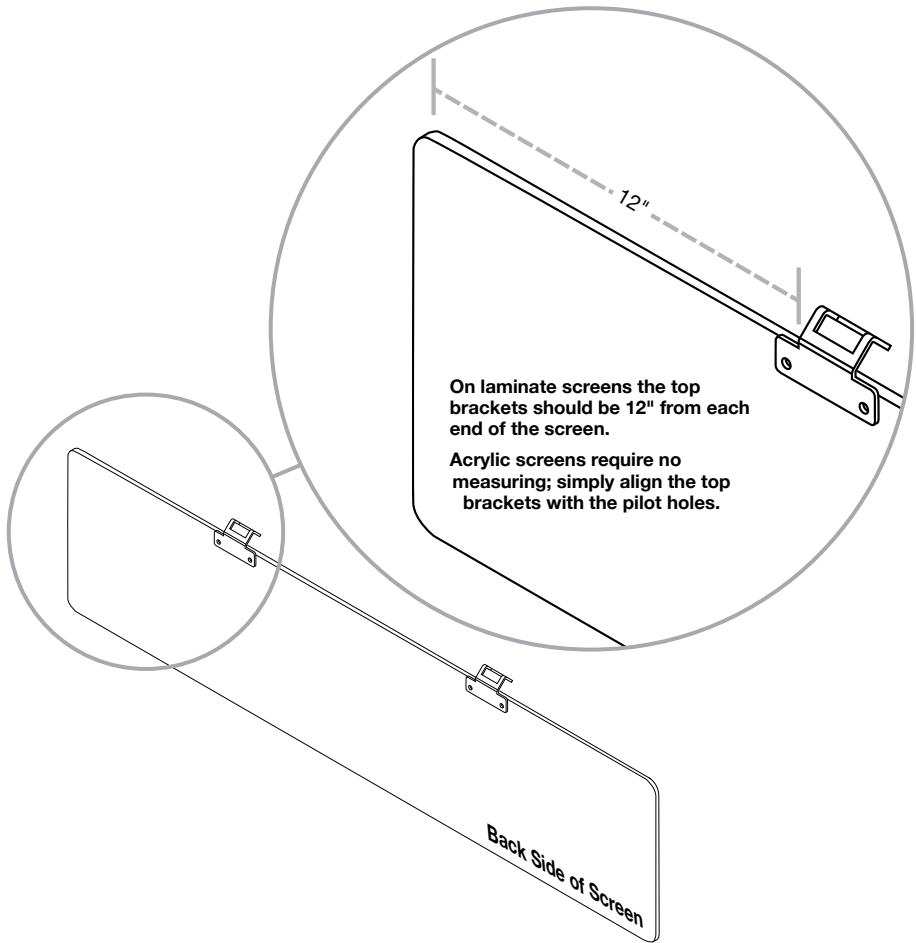

TOOLS

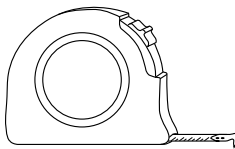

Measuring Tape

Step 2 (Laminate Only): Mark the position of the top brackets and drill $\frac{1}{2}$ " deep pilot holes.

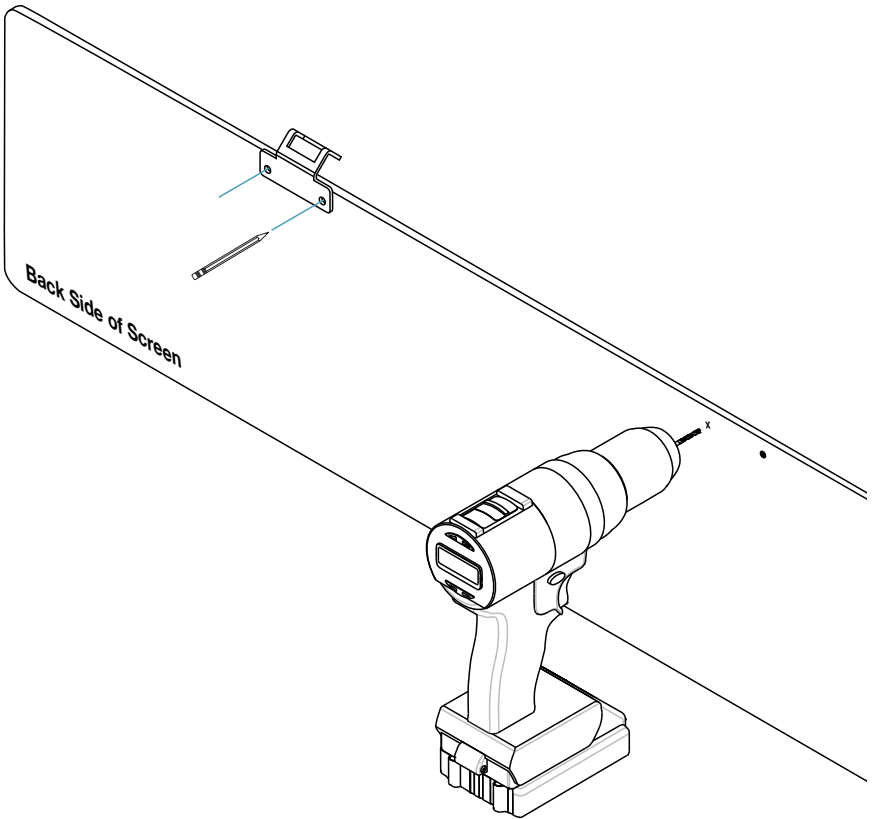

TOOLS

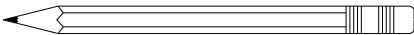

Pencil



$\frac{3}{32}$ " Drill Bit

Step 3 (Laminate): Attach the bottom brackets to the modesty screen.

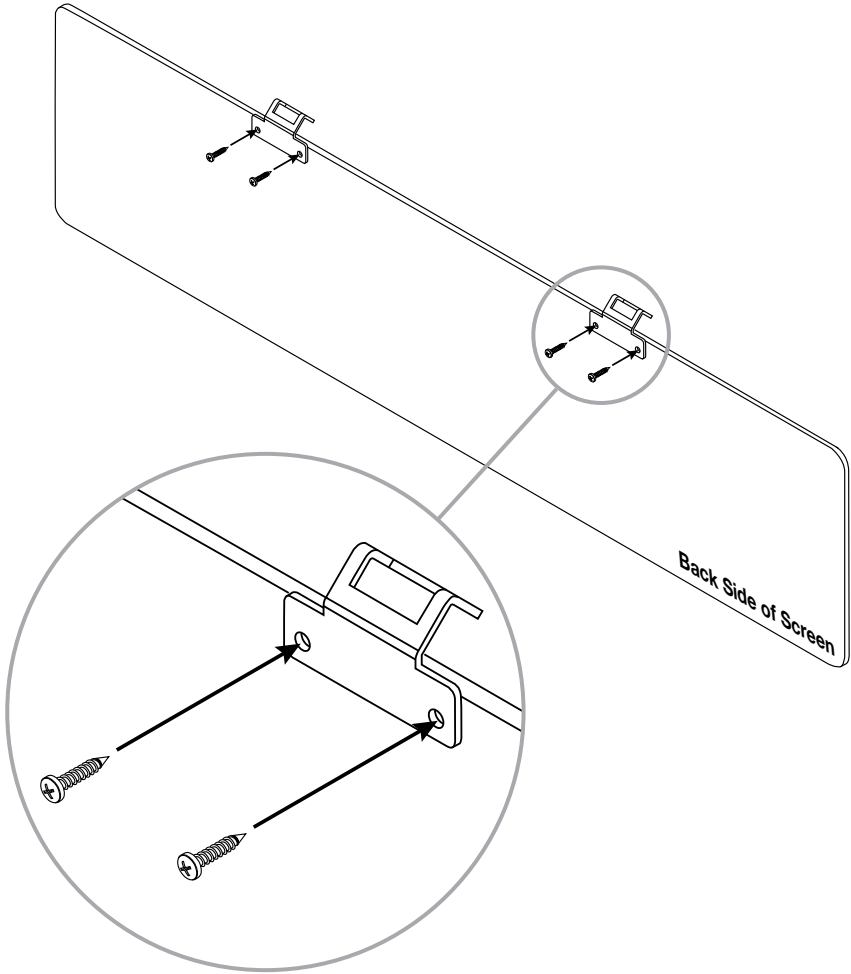

1:1 HARDWARE

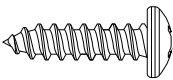

#10 x 3/4" Screw

TOOLS

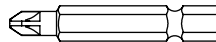

#2 Phillips Bit

Step 3 (Acrylic): Attach the bottom brackets to the modesty screen.

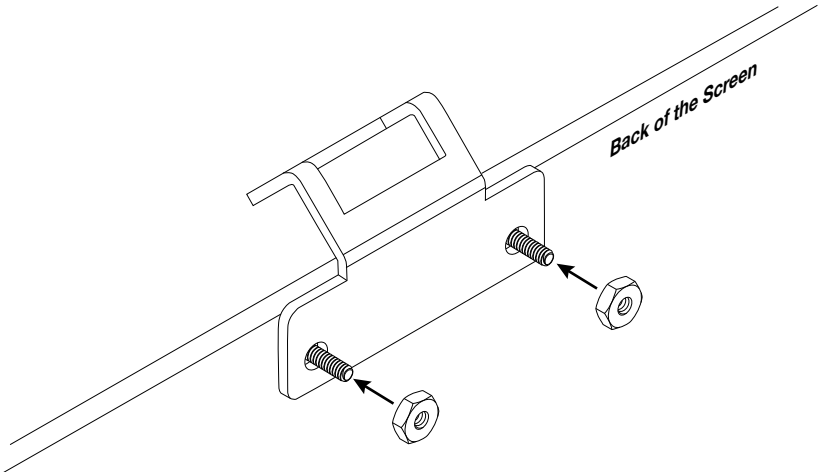
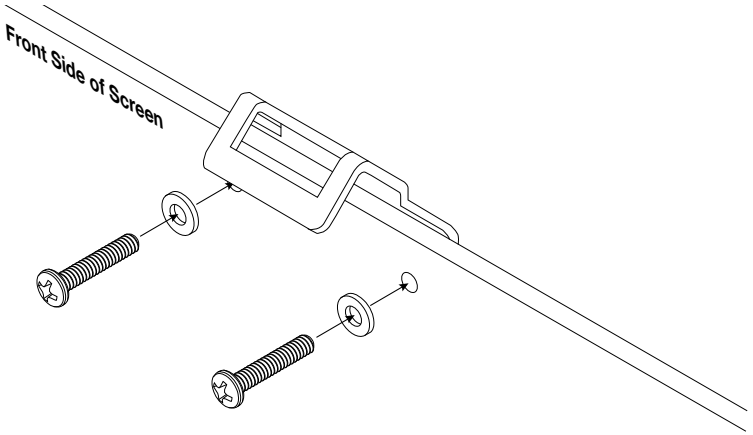

1:1 HARDWARE



#6 Flat Washer



#6-32 x 3/4" Screw



#6 Hex Nut

Modesty Screen HINGED ASSEMBLY INSTRUCTIONS

Step 4: Attach the bottom brackets through the tabbed side of the top brackets. Position the bracket assembly on the underside of the table surface. Mark where the top brackets will attach.

Detach the bottom brackets from the top brackets before step 5.

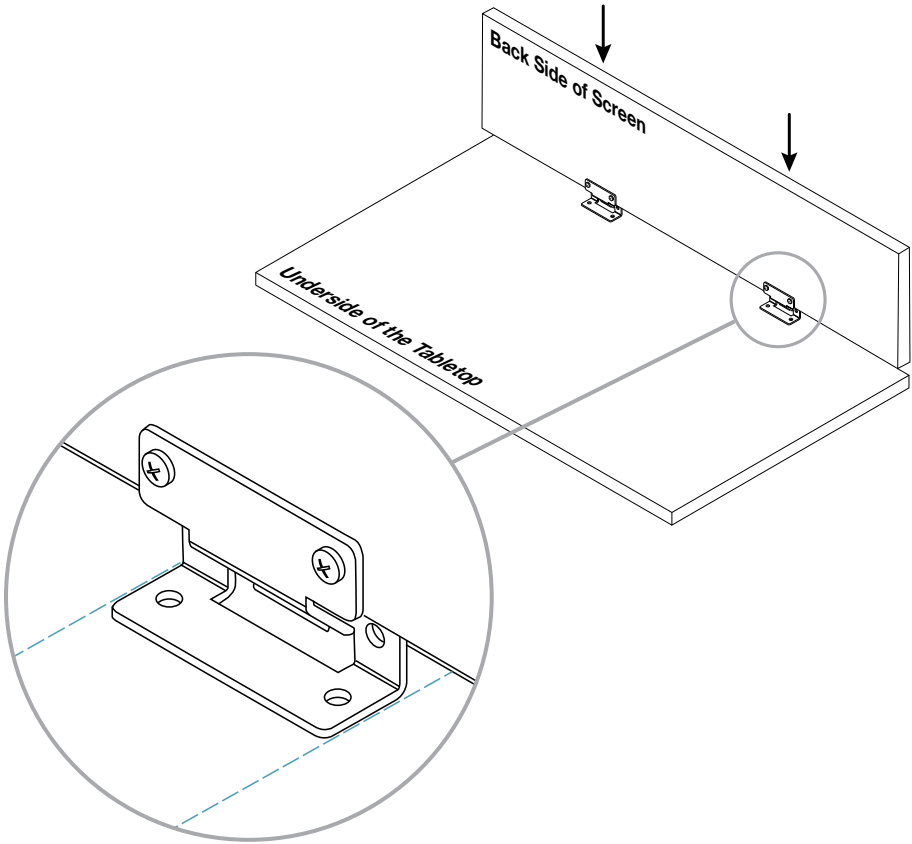

TOOLS

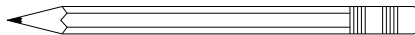

Pencil

Step 5: Mark the location of the top bracket's holes and drill $\frac{1}{2}$ " deep pilot holes into the underside of the tabletop.

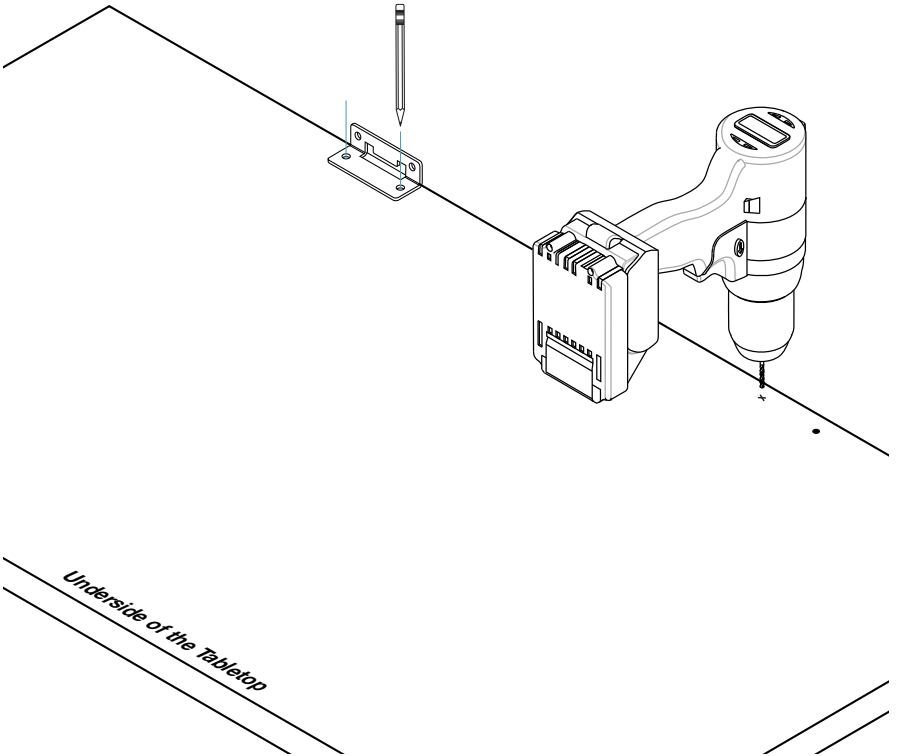

TOOLS

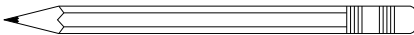

Pencil



$\frac{3}{32}$ " Drill Bit

Step 6: Attach the top brackets to the underside of the tabletop.

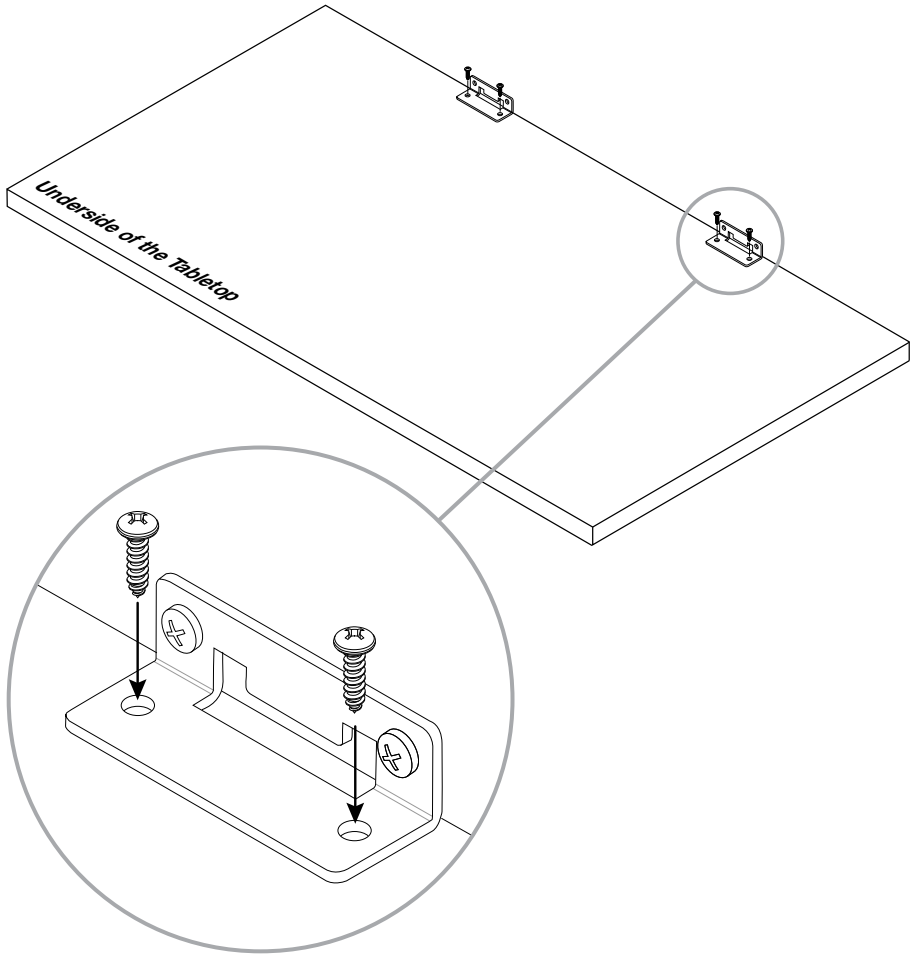

1:1 HARDWARE

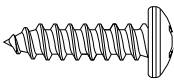

#10 x 3/4" Screw

TOOLS

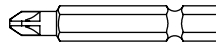

#2 Phillips Bit

Step 7: With the tabletop right-side up, hang the screen, inserting the bottom brackets into the top brackets.

