

# SECTOR

## ACRYLIC TABLETOP SCREENS

### ASSEMBLY INSTRUCTIONS

Partition and protect. Now more than ever, our shared spaces should be safe—free from contagions, concerns and anything that gets in the way of interacting. This collection of acrylic tabletop screens provides the protection and peace of mind you need to socialize with confidence.

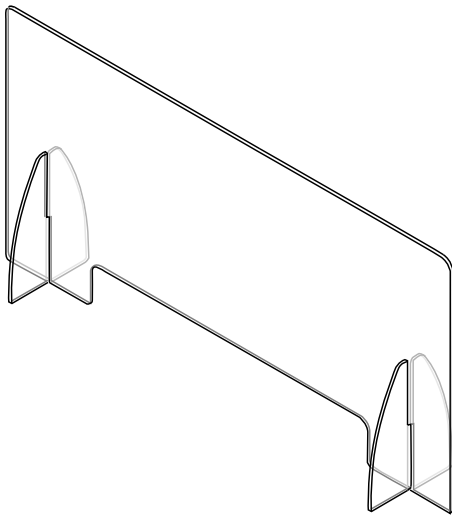

**TRANSACTION WITH PASSTHROUGH**

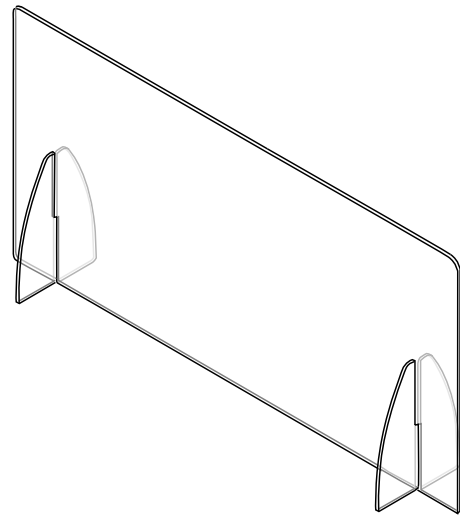

**TRANSACTION WITHOUT PASSTHROUGH**

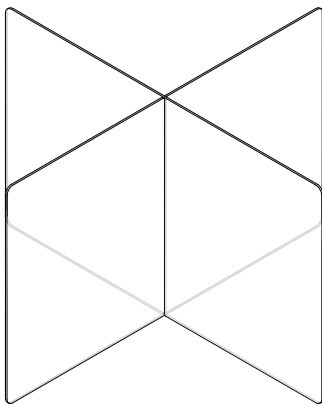

**4-PERSON CAFÉ**

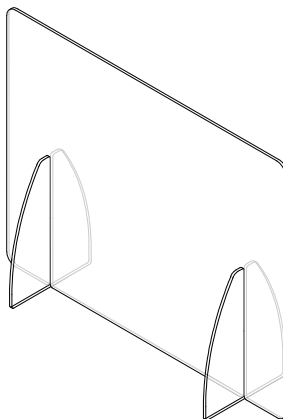

**2-PERSON CAFÉ**

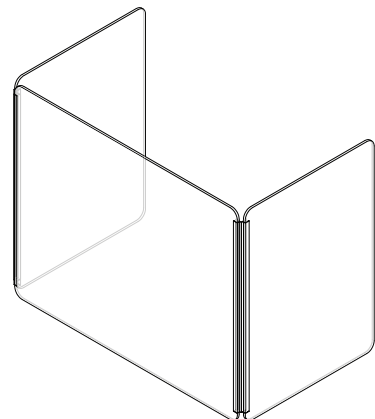

**TRI-FOLD MEETING**

# SECTOR ACRYLIC TABLETOP SCREEN ASSEMBLY INSTRUCTIONS

## COMPONENT LIST

### Transaction With Passthrough:

- Screen Panel (1)
- Foot (2)

### Transaction Without Passthrough:

- Screen Panel (1)
- Foot (2)

### 2-Person Café:

- Screen Panel (1)
- Foot (2)

### 4-Person Café:

- Screen Panel (2)

### Tri-Fold Meeting:

- Screen Panel (1)

*Note: Do not remove the protective film from the acrylic until the screen is put into service.*

## COMPONENTS

### TRANSACTION WITH PASSTHROUGH

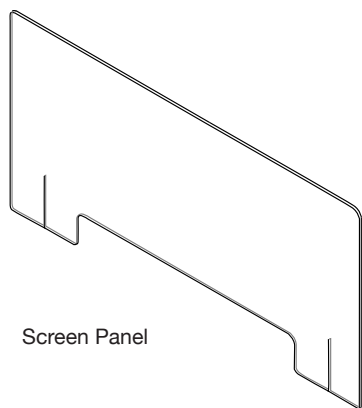

Screen Panel

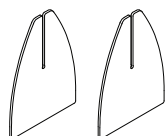

Feet

### TRANSACTION WITHOUT PASSTHROUGH

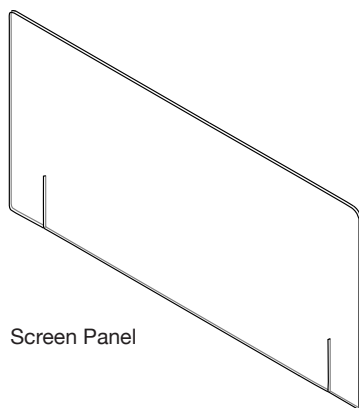

Screen Panel

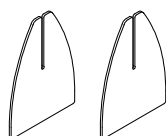

Feet

### 2-PERSON CAFÉ

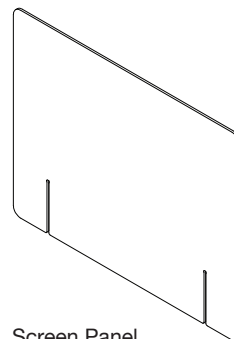

Screen Panel

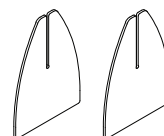

Feet

### ALTERNATE BASE TYPES

*(For transaction and 2-person café screens)*

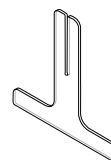
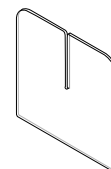

### TRIFOLD MEETING



Tri-Fold Meeting Screen

### 4-PERSON CAFÉ

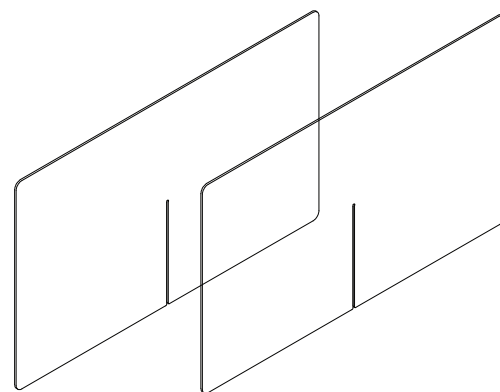

Screen Panels

# SECTOR ACRYLIC TABLETOP SCREEN ASSEMBLY INSTRUCTIONS

## 1 TRANSACTION WITH OR WITHOUT PASSTHROUGH AND 2-PERSON CAFÉ

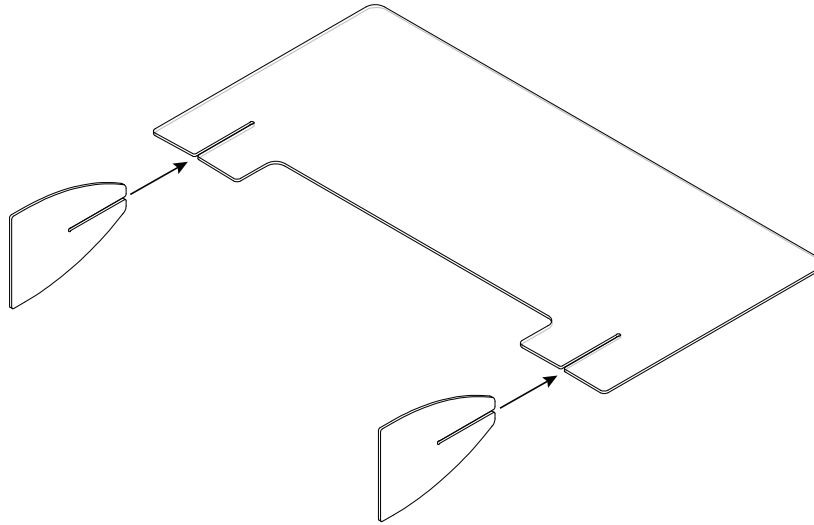

## 2

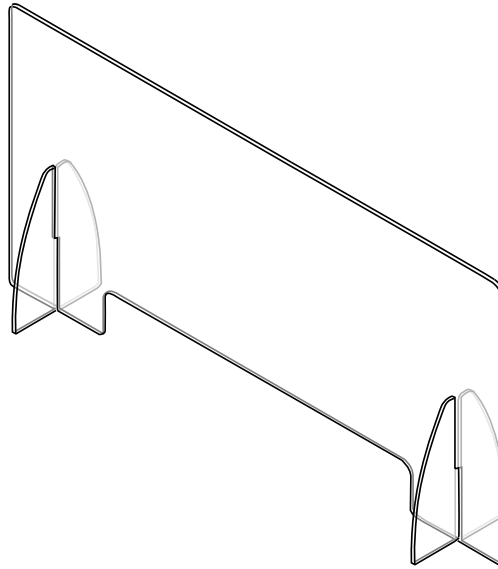

### STEPS

1. Lay screen panel on the edge of a firm, flat surface. Insert feet into the slots at the bottom of the screen panel.
2. Stand screen upright on desired surface, resting it on its feet. Ensure complete screen assembly rests flat on the surface.

# SECTOR ACRYLIC TABLETOP SCREEN ASSEMBLY INSTRUCTIONS

## 1 4-PERSON CAFÉ

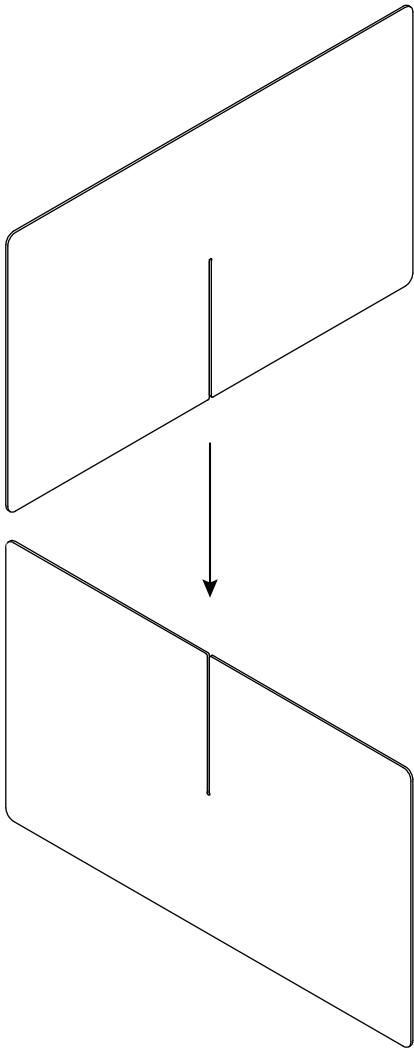

## 2

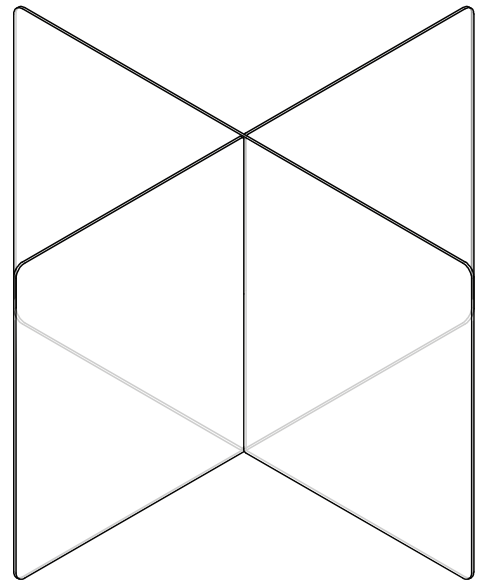

### STEPS

1. Hold one panel vertically with the center slot facing upwards. Insert second screen panel with the center slot facing down.
2. Ensure assembly forms a perpendicular “+” shape with the first panel. The complete screen assembly should rest flat on desired surface.

# SECTOR ACRYLIC TABLETOP SCREEN ASSEMBLY INSTRUCTIONS

## 1 TRI-FOLD MEETING



## 2

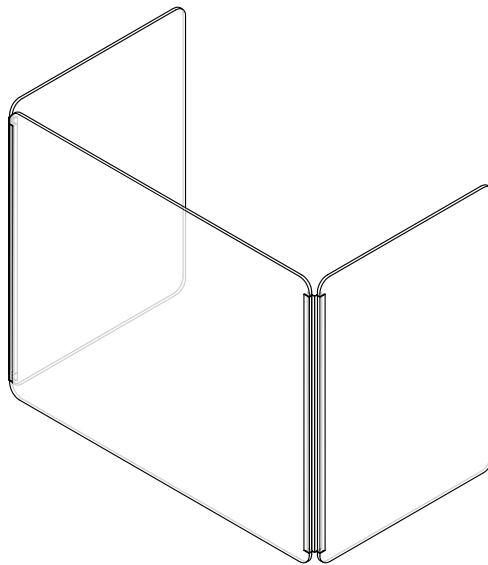

## STEPS

1. Place screen panel assembly onto a firm, flat surface.
2. Unfold outer panels into position, forming 45–90 degree corners with the center panel. Ensure complete screen assembly rests flat on desired surface.