

Parallon

GANGING BRACKET GUIDE

Everything to the table.

When you want cohesion in spaces large, small, shared or separate, there's Parallon. It's a single collection with a singular look, offering an array of choices for a variety of environments—and all the features to fit. Continue the cohesion even when it's time to “take five” from meeting or training. Our café + occasional tables help carry the design into your casual and touch-down spaces.



Read the entire instruction manual before you start installation and assembly. If you have any questions regarding any of the instructions or warnings, please contact your local distributor for assistance.

To report any issues with this product, contact our customer experience team at: (888) 274-8664 or sitonit@exemplis.com.

Recommended Tools

- Cordless Drill/Driver
- #2 Phillips Bit

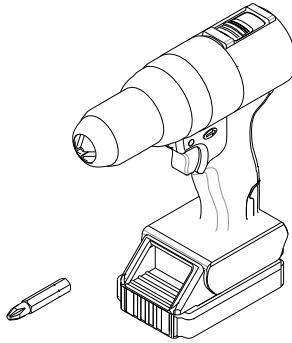

Parts

- Ganging Bracket (2)
- M4 x 30 mm Screw (8)

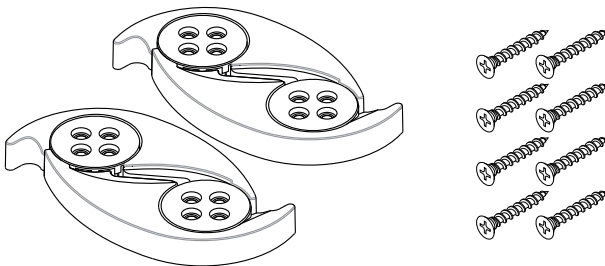

Step 1: Open the ganging bracket and separate it into its two pieces.

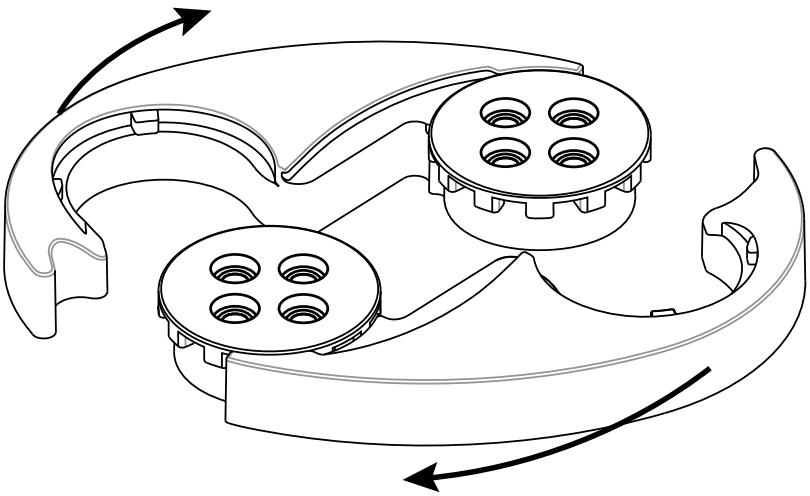

Step 2: Attach one half of the ganging bracket to the underside of the table and the other half to the table you're ganging the first table to.

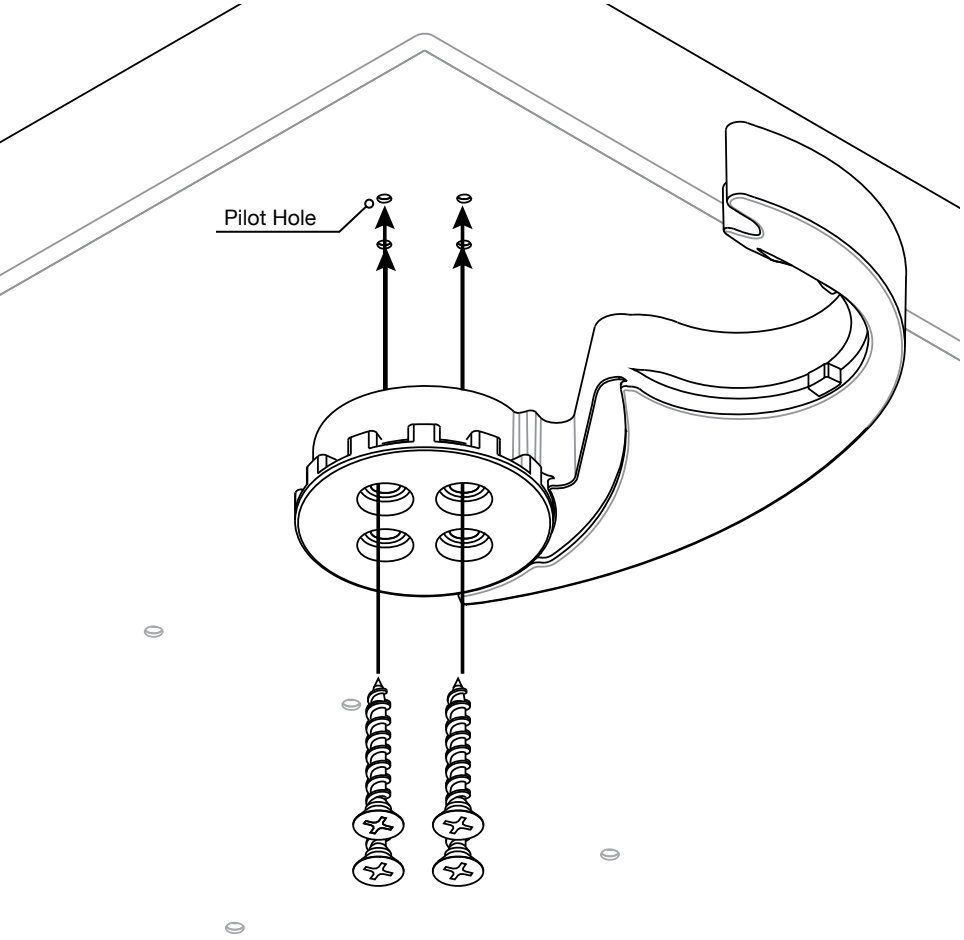

1:1 HARDWARE

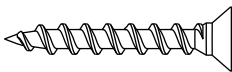

M4 x 30 mm Screw

TOOLS

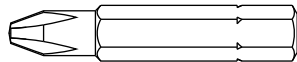

#2 Phillips Bit

Step 3: Align the ganging bracket halves across from each other.

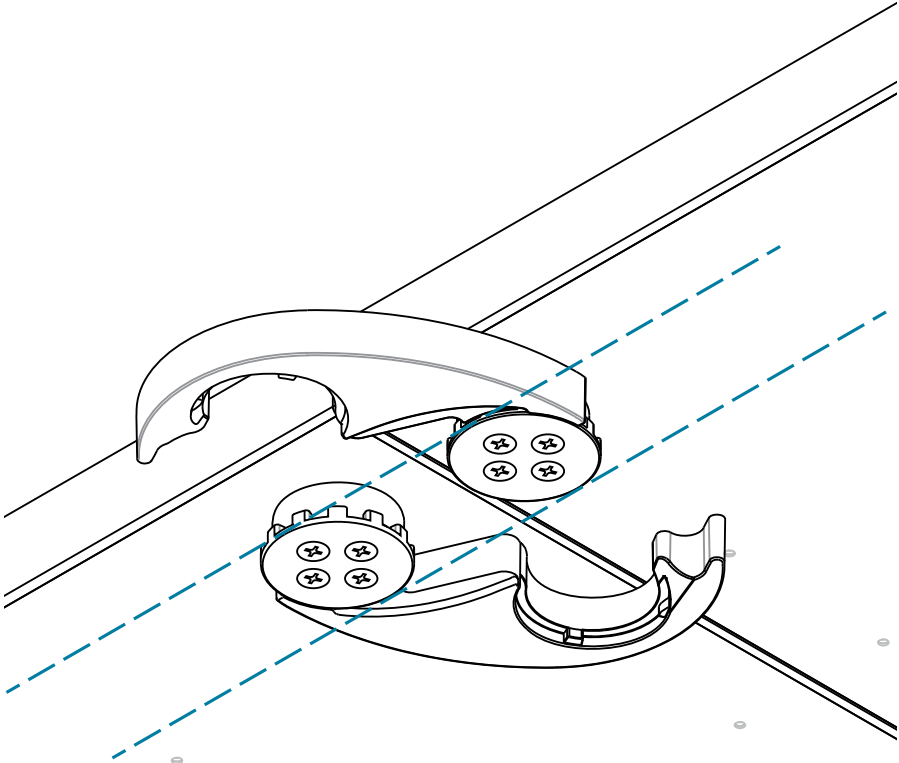

Step 4: Close the ganging brackets.

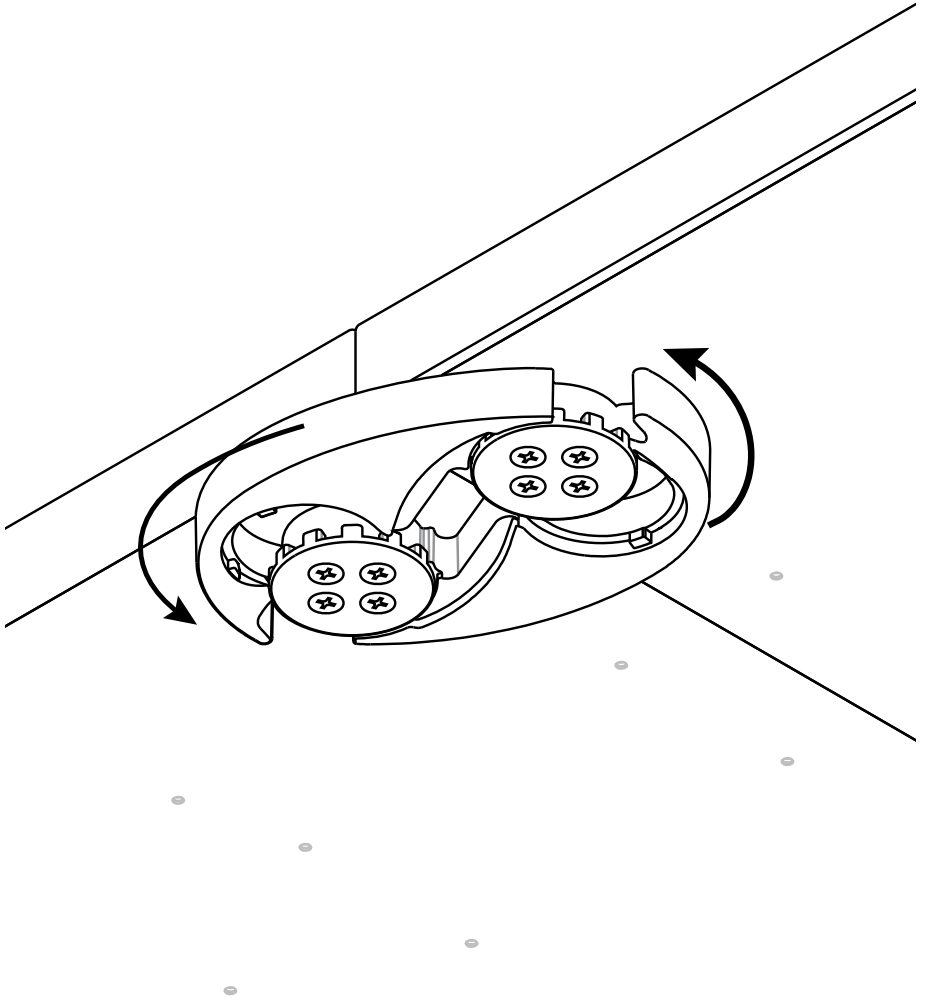

Ganging brackets: Attachment points

NUMBER OF ATTACHMENT POINTS

	Flat Edge	Knife Edge (Front Only)	Knife Edge (Front and Back)
Flip-Top Rectangle, T-Leg			
18" (D) x 42"-66" (W)	10	6	2
18" (D) x 72" (W)	8	6	2
24" Deep	10	6	2
30" Deep	12	8	4
36" Deep	12	8	4
Fixed-Top Rectangle, T-Leg			
18" Deep	12	8	4
24" Deep	12	8	4
30" Deep	12	8	4
36" Deep	12	8	4
Fixed-Top Rectangle, C-Leg			
18" Deep	8	4	2
24" Deep	8	4	2
30" Deep	12	8	4
Half Round, All Bases			
24" Deep	6	4	N/A
30" Deep	6	4	N/A
Trapezoid, All Bases			
24" Deep	6	4	2
30" Deep	6	4	2

Knife-edged rectangular tabletops on a C-Leg base can only gang back-to-back if the tabletop has a depth of 30".

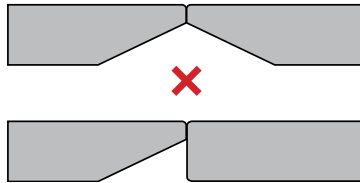

The number of ganging bracket attachment points varies because tables cannot gang together on a knife edged side.

Attachment Points

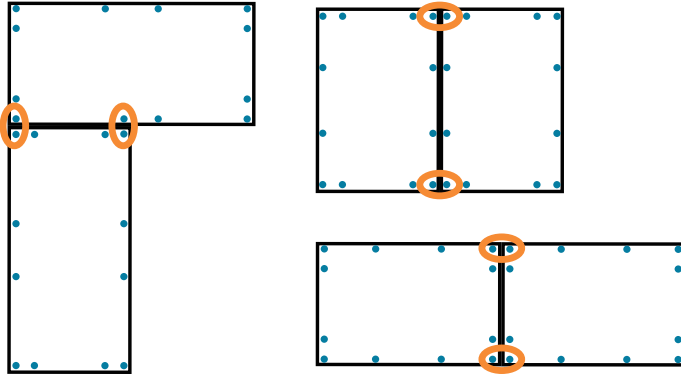

Sample Layout With Rectangles

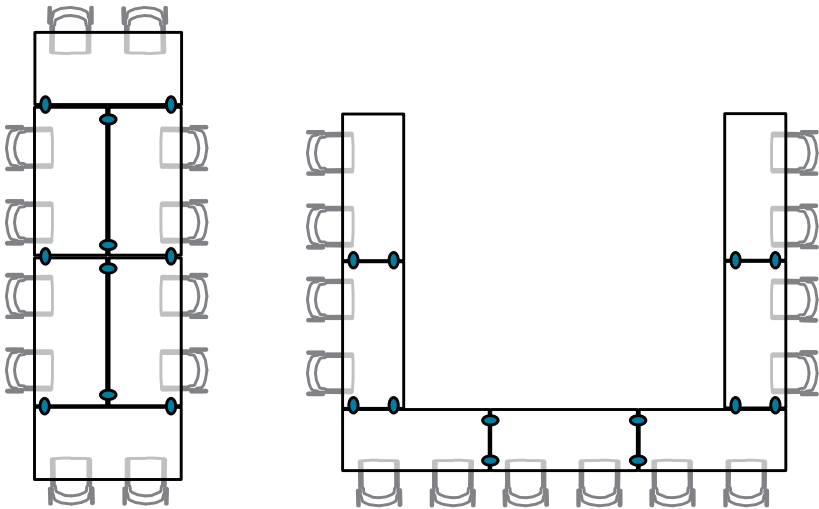

Attachment Points

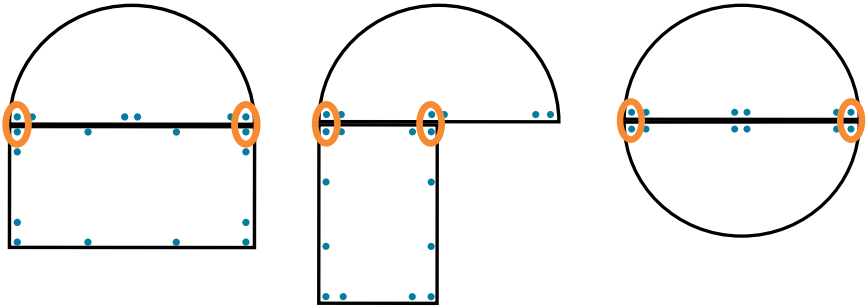

Sample Layouts With Half Rounds

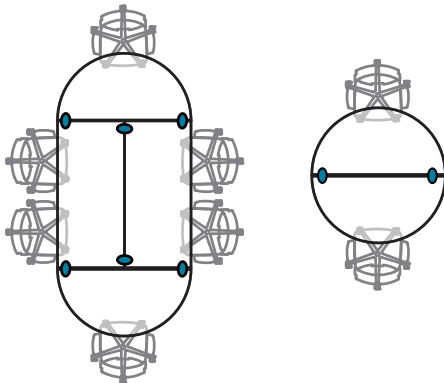

Attachment Points

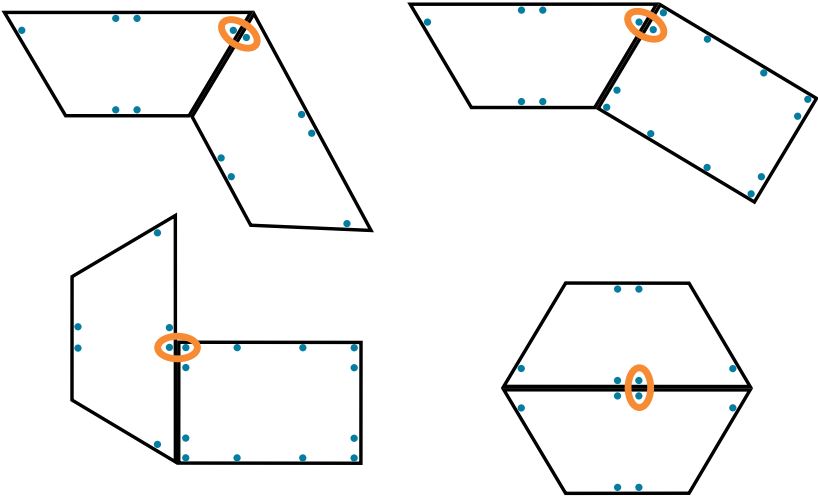

Sample Layout With Trapezoids

