

Parallon

FIXED TOP T-LEG TABLE ASSEMBLY INSTRUCTIONS

Everything to the table.

When you want cohesion in spaces large, small, shared or separate, there's Parallon. It's a single collection with a singular look, offering an array of choices for a variety of environments—and all the features to fit.

Ensure design is never a distraction in the places where everyone needs to focus. Our Parallon line of training tables provides a unified and streamlined look from room to room.

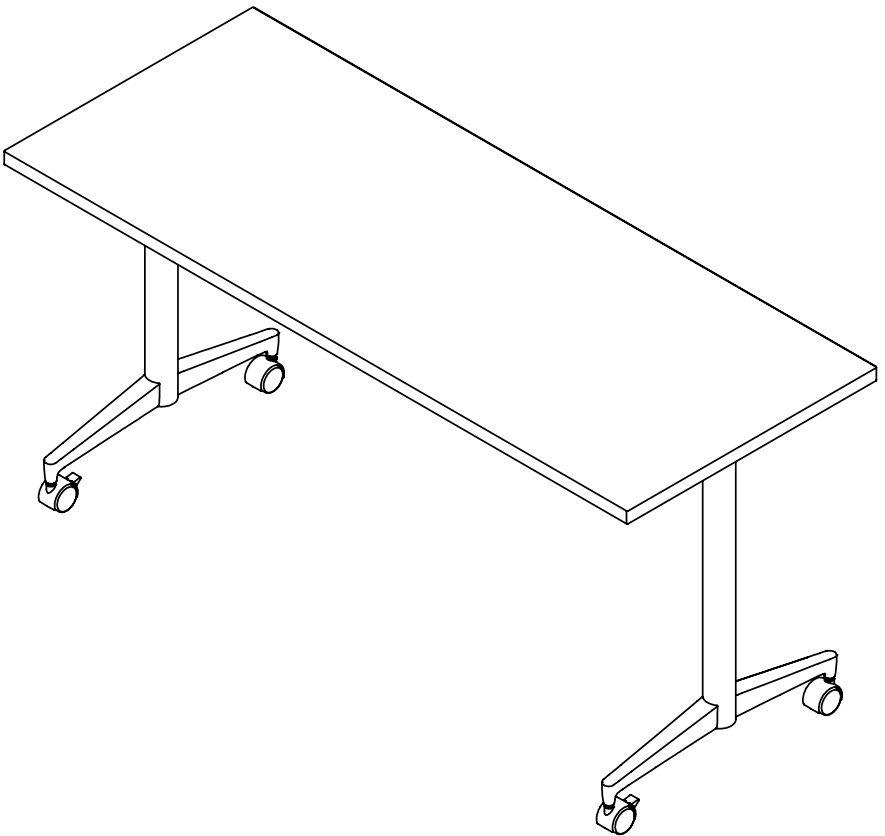

Read the entire instruction manual before you start installation and assembly. If you have any questions regarding any of the instructions or warnings, please contact your local distributor for assistance.

To report any issues with this product, contact our customer experience team at: (888) 274-8664 or sitonit@exemplis.com.



CAUTION

Failure to follow instructions could result in product failure or potential injury.

Do not apply sudden weight to table.

Do not exceed 200 lb static load weight capacity.

Keep fingers clear of pinch points.

Recommended Tools

- Cordless Drill/Driver
- #3 Phillips Bit
- 5/32" Hex Bit
- 1/2" Combination Wrench
- 1/2" Deep Well Hex Socket, 1/4" Drive
- Hex Shank to 1/4" Square Drive Adapter
- 1/4" Drive Universal Joint

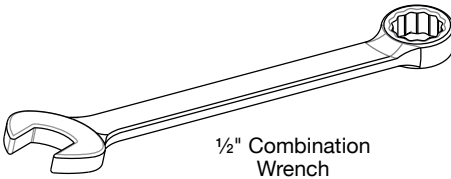

Universal Joint
1/4" Drive

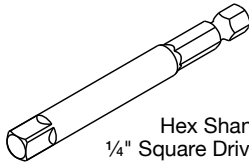

Hex Shank to
1/4" Square Drive Adapter

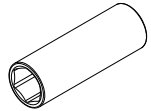

1/2" Deep Well Hex
Socket, 1/4" Drive

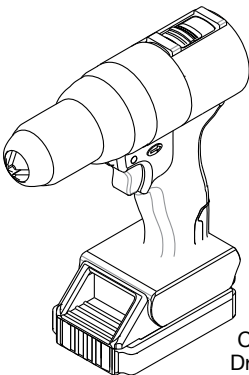

Cordless
Drill/Driver

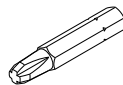

#3 Phillips Bit

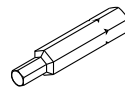

5/32" Hex Bit

Parts: Top and Frame

- Tabletop (1, rectangular, half round or trapezoid)
- Top Plates (2)
- Grommet (optional)
- **Pack A:**
 - #12 × 1" Screw (17)
- **Pack C:**
 - ¼" × 1" Screw (8)

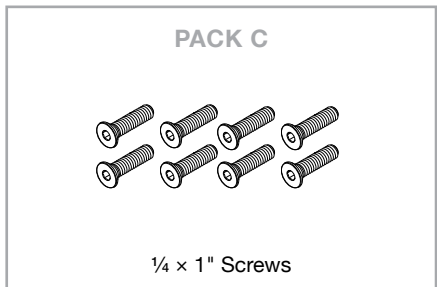
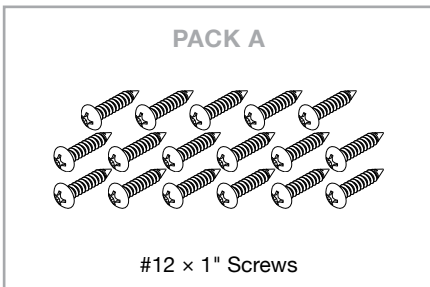
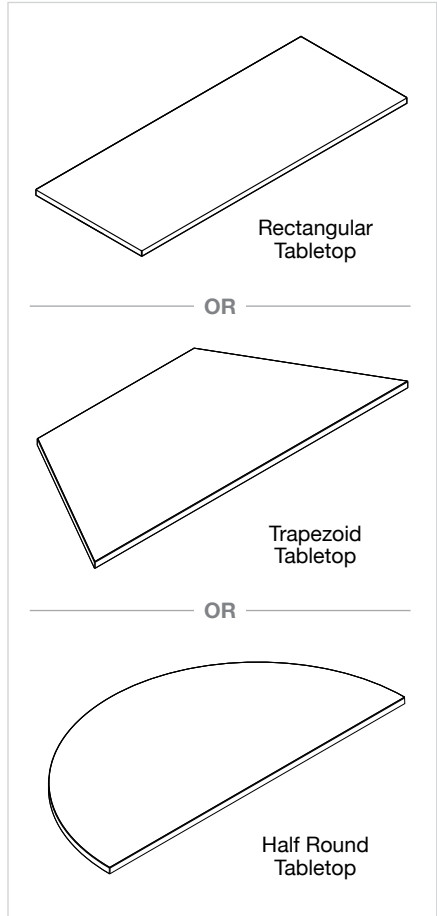
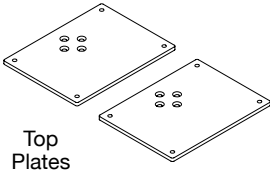

Parts: Columns and Feet

- Column (2)
- Foot (4)
- Caster (4, optional)
- **Pack B:**
 - $\frac{5}{16}$ " \times $1\frac{1}{2}$ " Bolt (4)
 - $\frac{5}{16}$ " Nut (4)
 - Foot Attachment Plate (4)

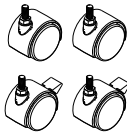

Casters (Optional)

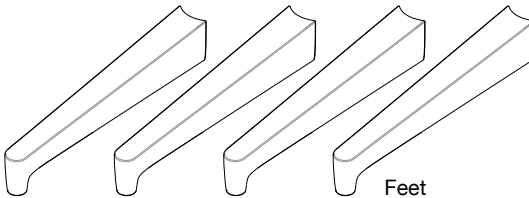

Feet

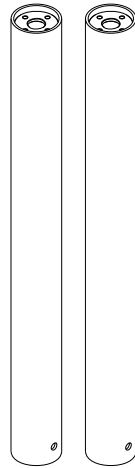

Columns

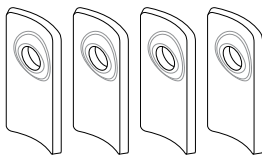

Foot Attachment Plates

PACK B



$\frac{5}{16}$ " Nuts

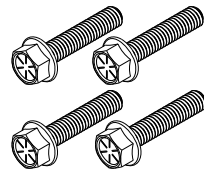

$\frac{5}{16}$ \times $1\frac{1}{2}$ " Bolts

Step 1: Attach the top plates to the columns.

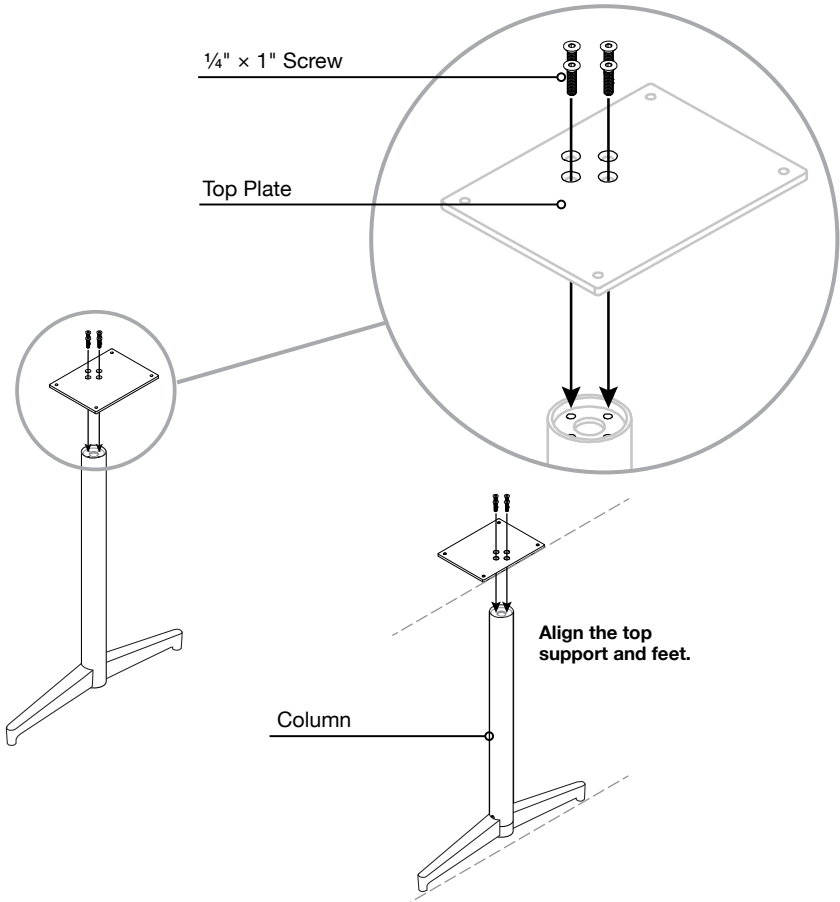

1:1 HARDWARE

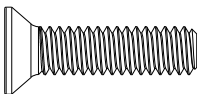

1/4 x 1" Screw (Pack C)

TOOLS

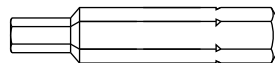

5/32 Hex Drill Bit

Step 2: Attach the column assemblies to the tabletop.

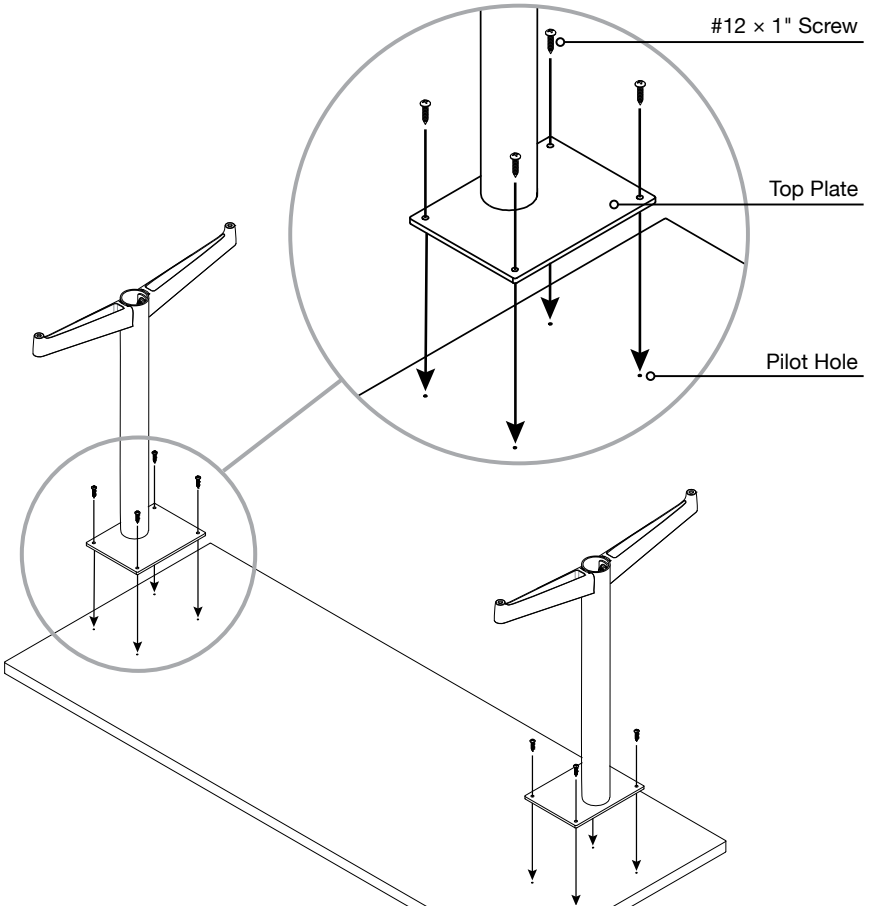

1:1 HARDWARE

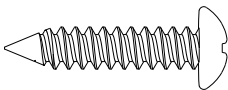

#12 x 1" Screw (Pack A)

TOOLS

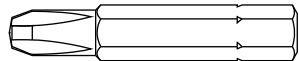

#3 Phillips Bit

Step 3: Slide the bolt through the foot attachment plate and column.

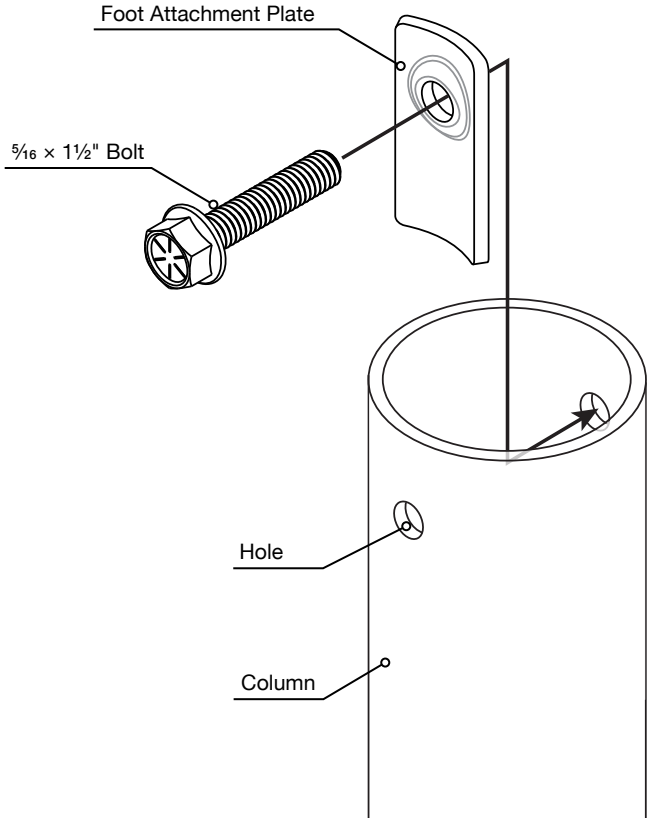

1:1 HARDWARE

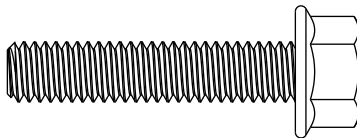

$\frac{5}{16} \times 1\frac{1}{2}$ " Bolt (Pack B)

Step 4: Slide the foot over the bolt.

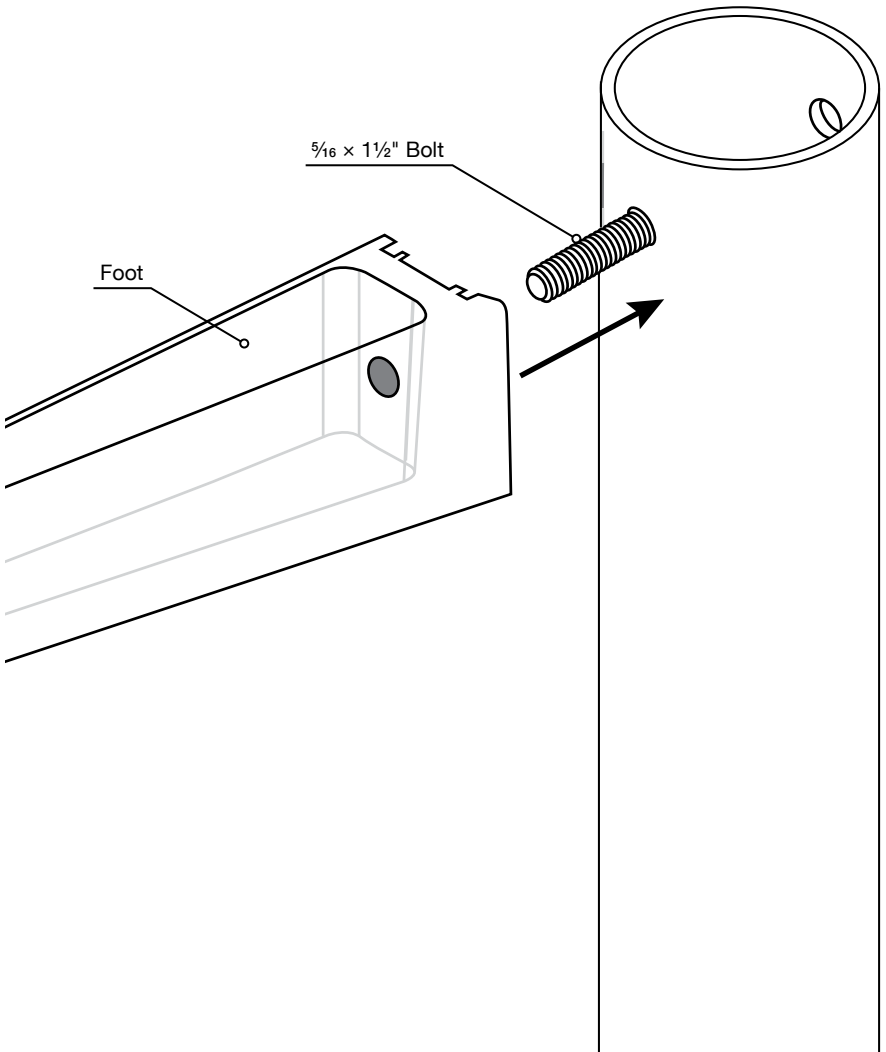

Step 5: Hold the bolt in place and tighten the nut.

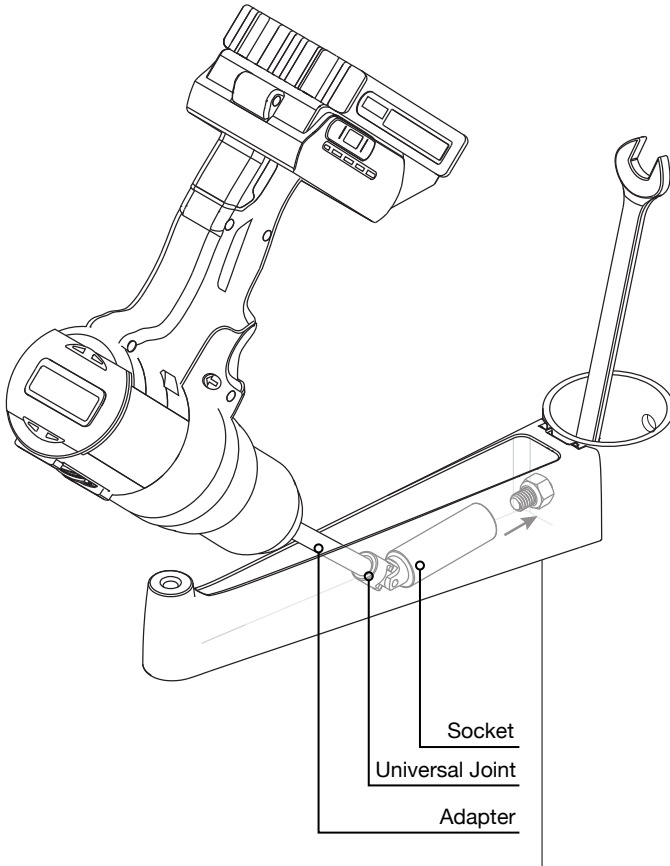

1:1 HARDWARE

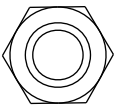

5/16 Nut (Pack B)

TOOLS



1/2" Deep Well Hex Socket,
1/4" Drive

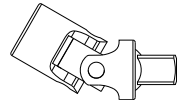

Universal Joint



Hex Shank to Square Drive Adapter

Step 6: Unscrew the glides to level as needed.
Alternatively, insert the optional casters into the feet and tighten the nuts.

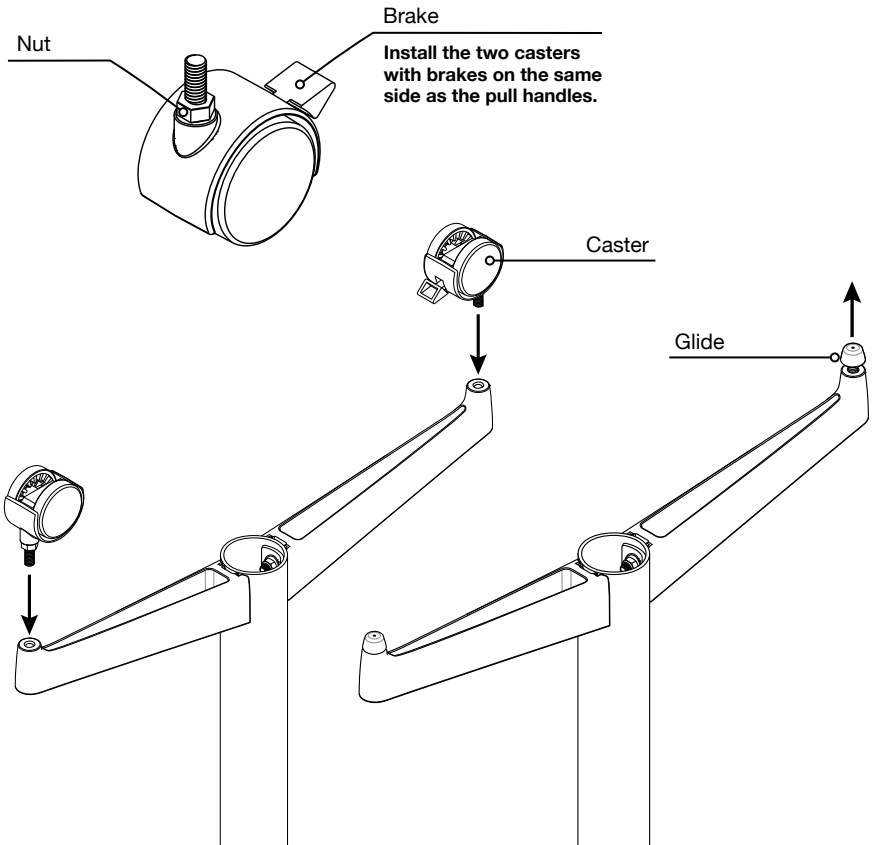

TOOLS



1/2" Combination Wrench

Step 7: Turn the table upright with the help of another person and if applicable, press the optional grommets into the cutouts.

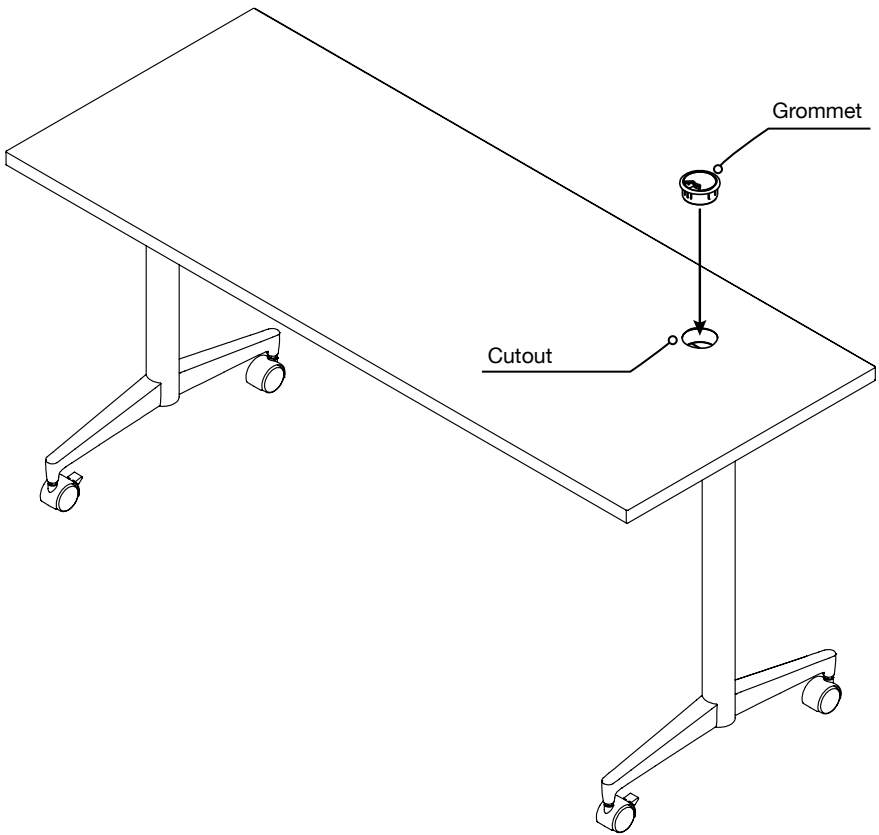

Parallon

FIXED TOP C-LEG TABLE ASSEMBLY INSTRUCTIONS

Everything to the table.

When you want cohesion in spaces large, small, shared or separate, there's Parallon. It's a single collection with a singular look, offering an array of choices for a variety of environments—and all the features to fit.

Ensure design is never a distraction in the places where everyone needs to focus. Our Parallon line of training tables provides a unified and streamlined look from room to room.

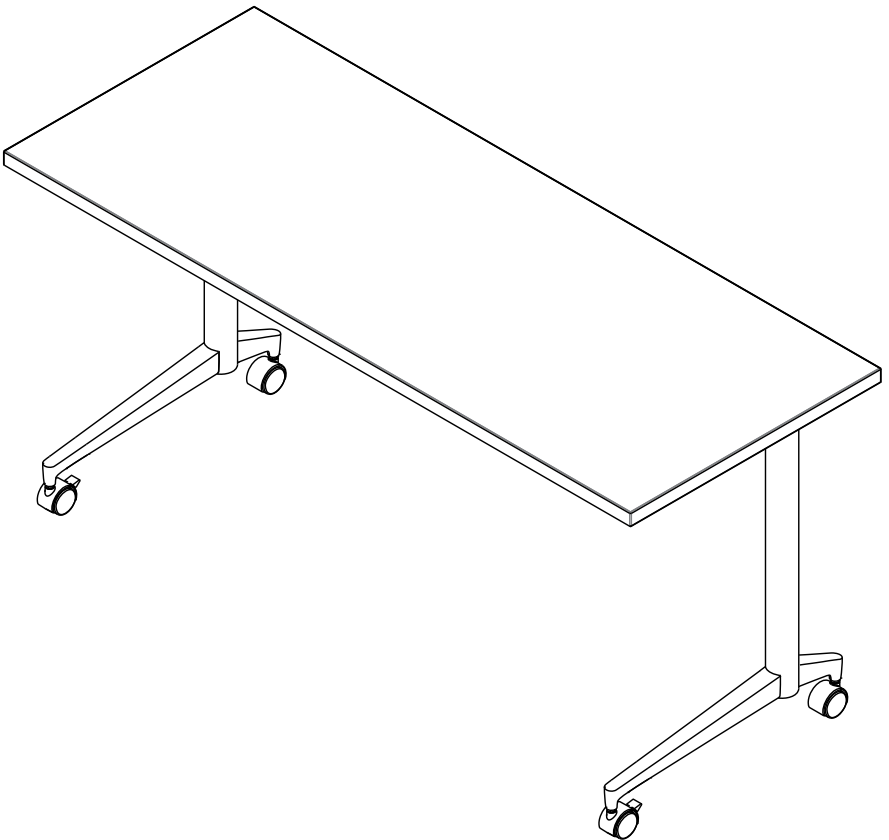

Read the entire instruction manual before you start installation and assembly. If you have any questions regarding any of the instructions or warnings, please contact your local distributor for assistance.

To report any issues with this product, contact our customer experience team at: (888) 274-8664 or sitonit@exemplis.com.



CAUTION

Failure to follow instructions could result in product failure or potential injury.

Do not apply sudden weight to table.

Do not exceed 200 lb static load weight capacity.

Keep fingers clear of pinch points.

Recommended Tools

- Cordless Drill/Driver
- #3 Phillips Bit
- 5/32" Hex Bit
- Magnetic Bit Holder
- 1/4" Hex L-Key (Optional)
- 1/2" Deep Well Hex Socket, 1/4" Drive
- Hex Shank to 1/4" Square Drive Adapter
- Universal Joint, 1/4" Drive
- 1/2" Combination Wrench

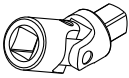

Universal Joint,
1/4" Drive

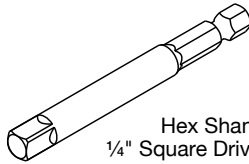

Hex Shank to
1/4" Square Drive Adapter

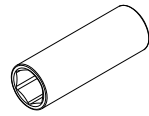

1/2" Deep Well Hex
Socket, 1/4" Drive

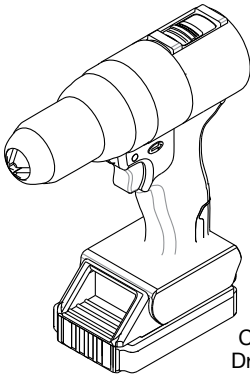

Cordless
Drill/Driver

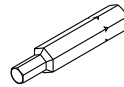

5/32" Hex Bit

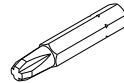

#3 Phillips Bit

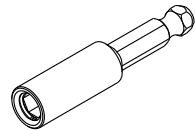

Magnetic Bit Holder

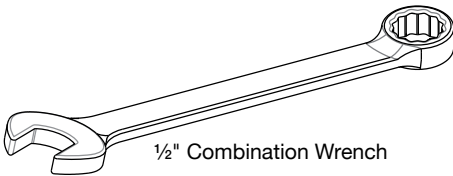

1/2" Combination Wrench

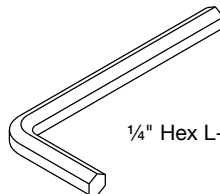

1/4" Hex L-Key

Parts: Top and Frame

- Tabletop (1, rectangular, half round or trapezoid)
- Top Plates (2)
- Grommet (optional)
- **Pack A:**
 - #12 × 1" Screw (17)
- **Pack C:**
 - ¼" × 1" Screw (8)

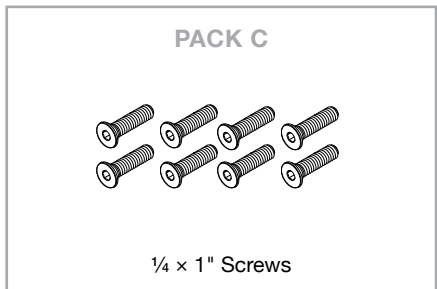
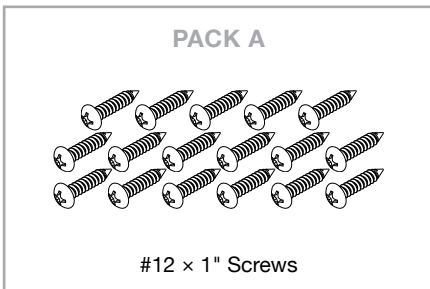
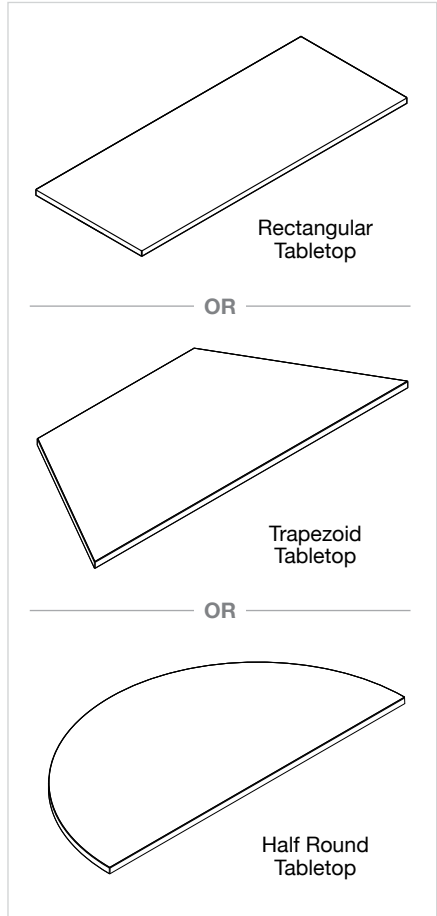
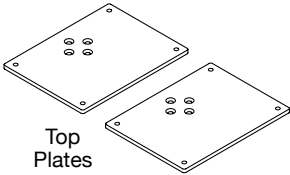

Parts: Columns and Feet

- Column (2)
- Long Foot (2)
- Short Foot (2)
- Caster (4, Optional)
- **Pack B:**
 - $\frac{5}{16}$ " Nut (2)
 - $\frac{5}{16}$ " x $1\frac{1}{2}$ " Bolt (Unused)
 - Foot Attachment Plate (Unused)
- **Pack D:**
 - Column Support (2)
 - $\frac{5}{16}$ x $3\frac{3}{4}$ " Screws

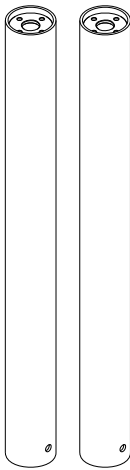

Columns

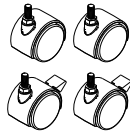

Casters
(Optional)

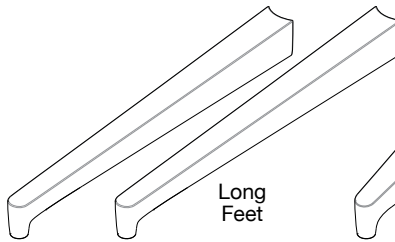

Long Feet

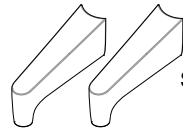

Short Feet

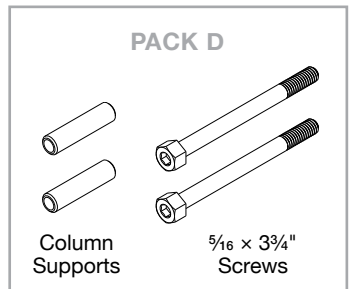
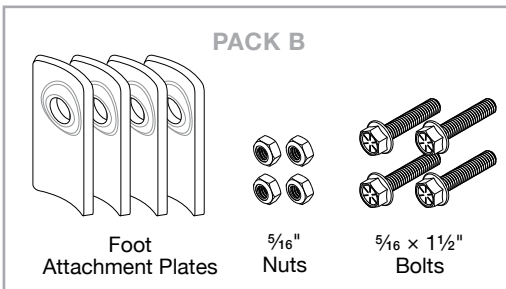

Step 1: Attach the top plates to the columns.

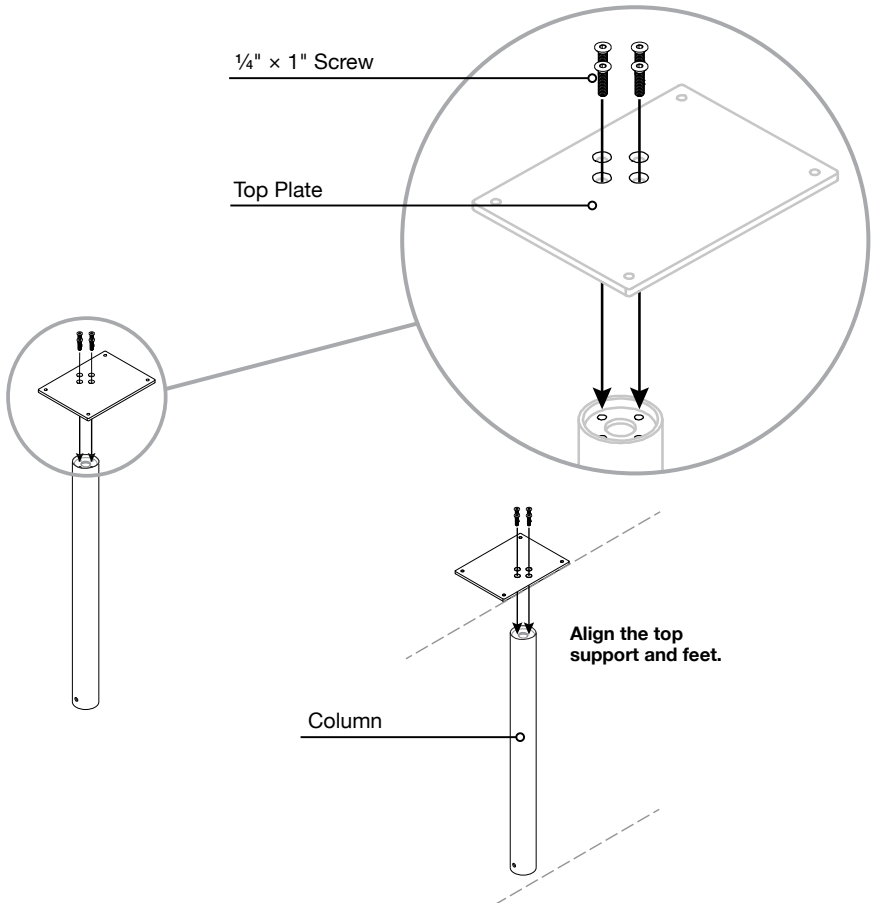

1:1 HARDWARE

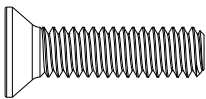

1/4 x 1" Screw (Pack C)

TOOLS

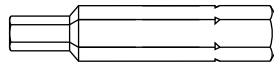

5/32 Hex Drill Bit

Step 2: Attach the column assemblies to the tabletop.

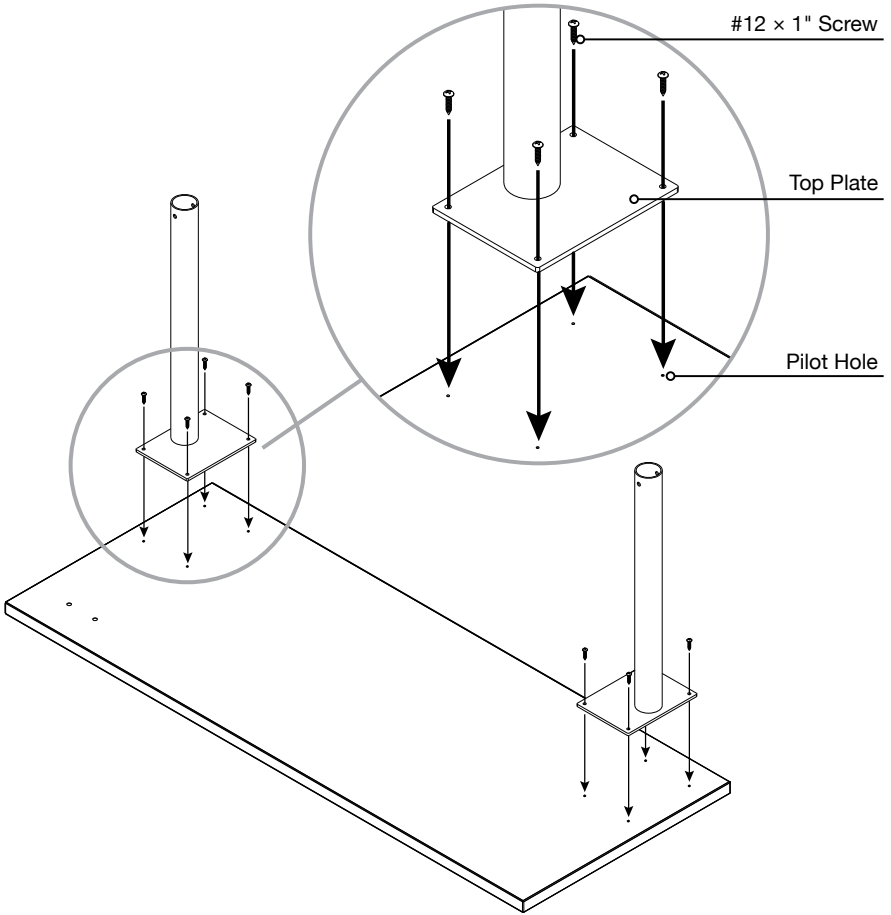

1:1 HARDWARE

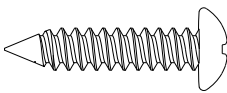

#12 x 1" Screw (Pack A)

TOOLS

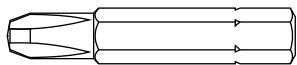

#3 Phillips Bit

Step 3: Insert the column support into the column and **hold it in place.**

Steps 3-5 will be repeated again on the opposite column.

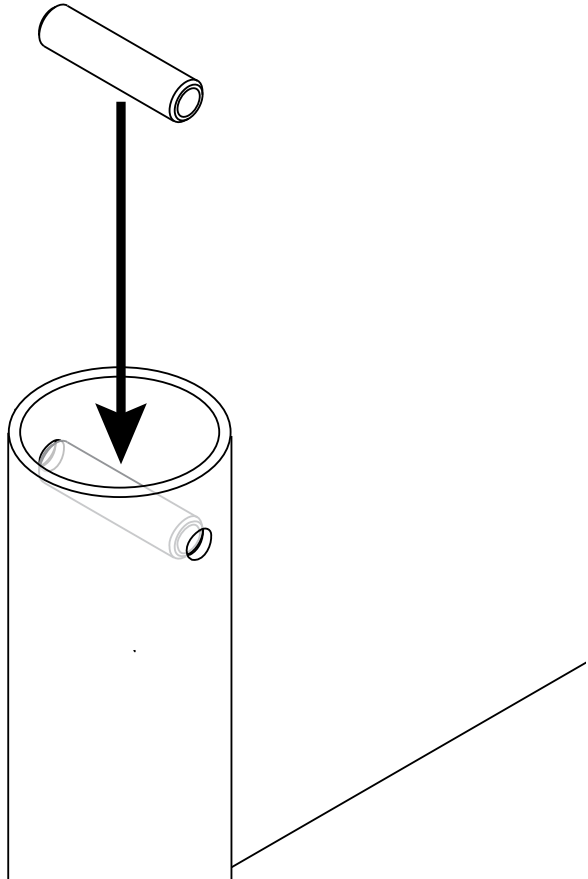

1:1 HARDWARE



Column Support (Pack D)

Step 4: Insert the bolt into the shorter leg, then through the column and column support.

Steps 3-5 will be repeated again on the opposite column.

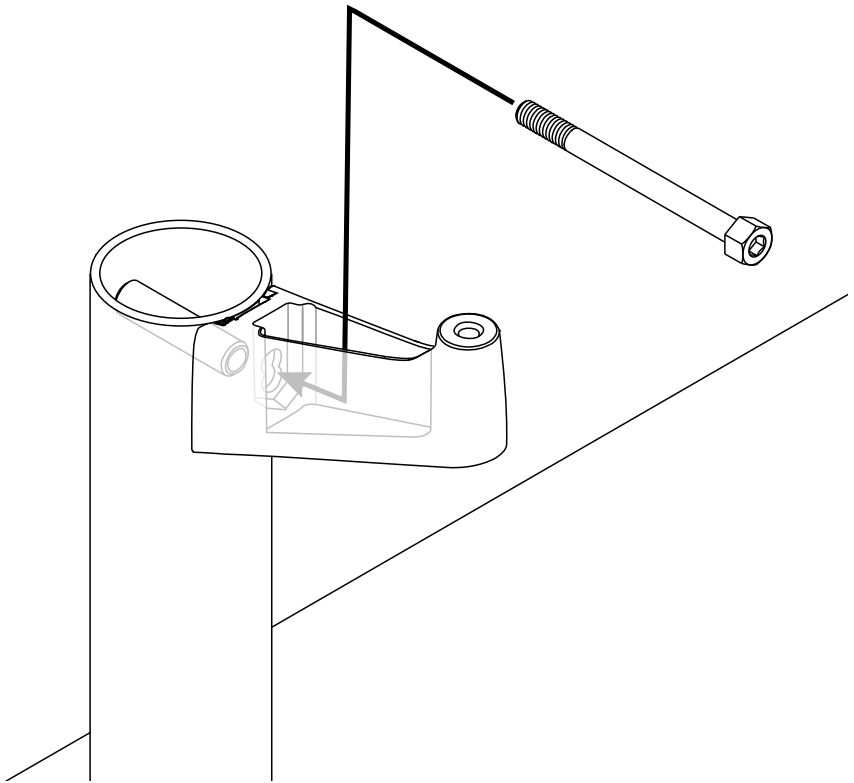

1:1 HARDWARE

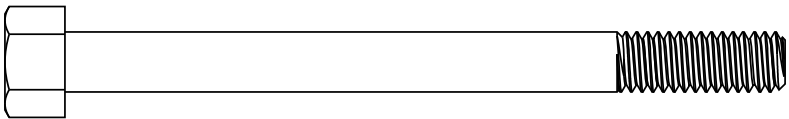

$\frac{5}{16} \times \frac{3}{4}$ " Screw

Step 5: In the long leg, tighten a nut over the bolt.

Steps 3-5 will be repeated again on the opposite column.

Note: A 1/4" hex key can be used to hold the head of the screw when tightening.

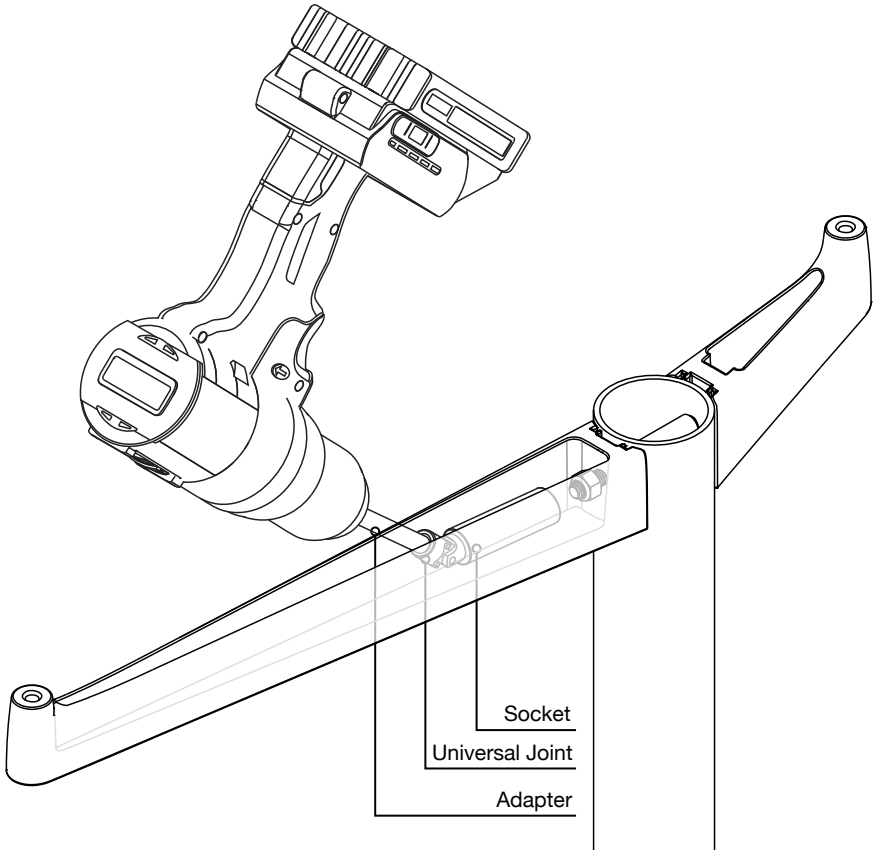

1:1 HARDWARE

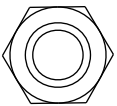

5/16 Nut (Pack B)

TOOLS



1/2" Deep Well Hex Socket,
1/4" Drive

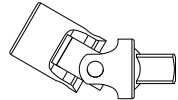

Universal Joint



Hex Shank to Square Drive Adapter

Step 6: Unscrew the glides to level as needed.
Alternatively, insert the optional casters into the feet and tighten the nuts.

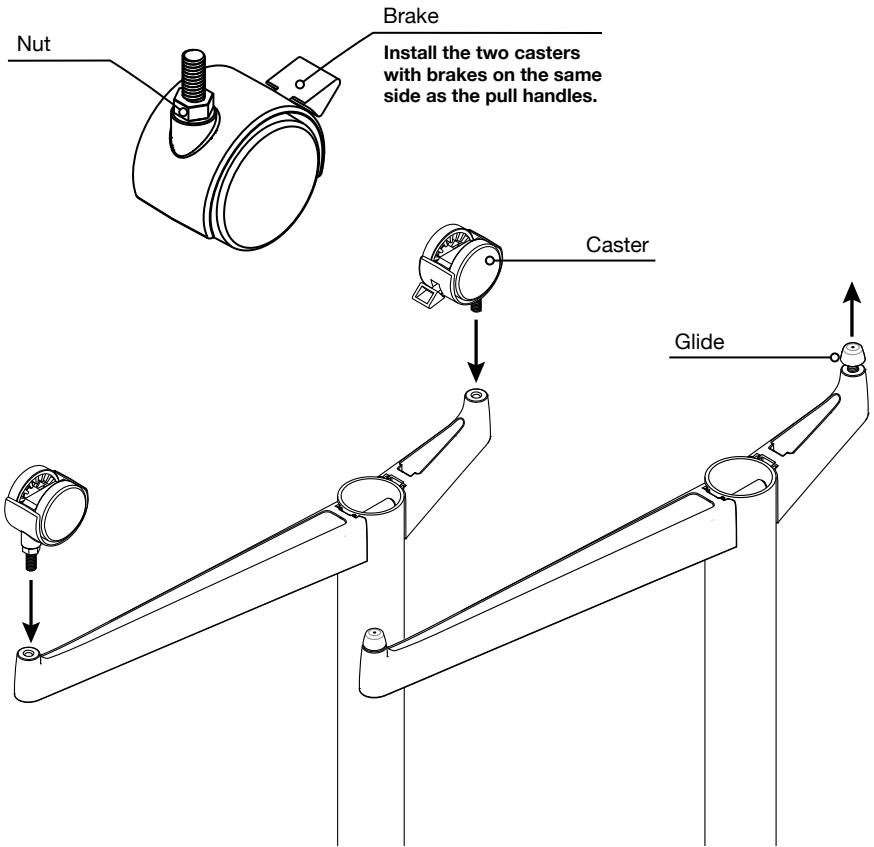

TOOLS



1/2" Combination Wrench

Step 7: Turn the table upright with the help of another person and if applicable, press the optional grommets into the cutouts.

