

KING COBRA - INSTALLATION MANUAL SitOnIt • Seating®

Light Duty and Heavy Duty Single Screen Powered Base Monitor Support

Single Light Duty (5-20 lbs capacity) / Single Heavy Duty (10-30 lbs capacity)

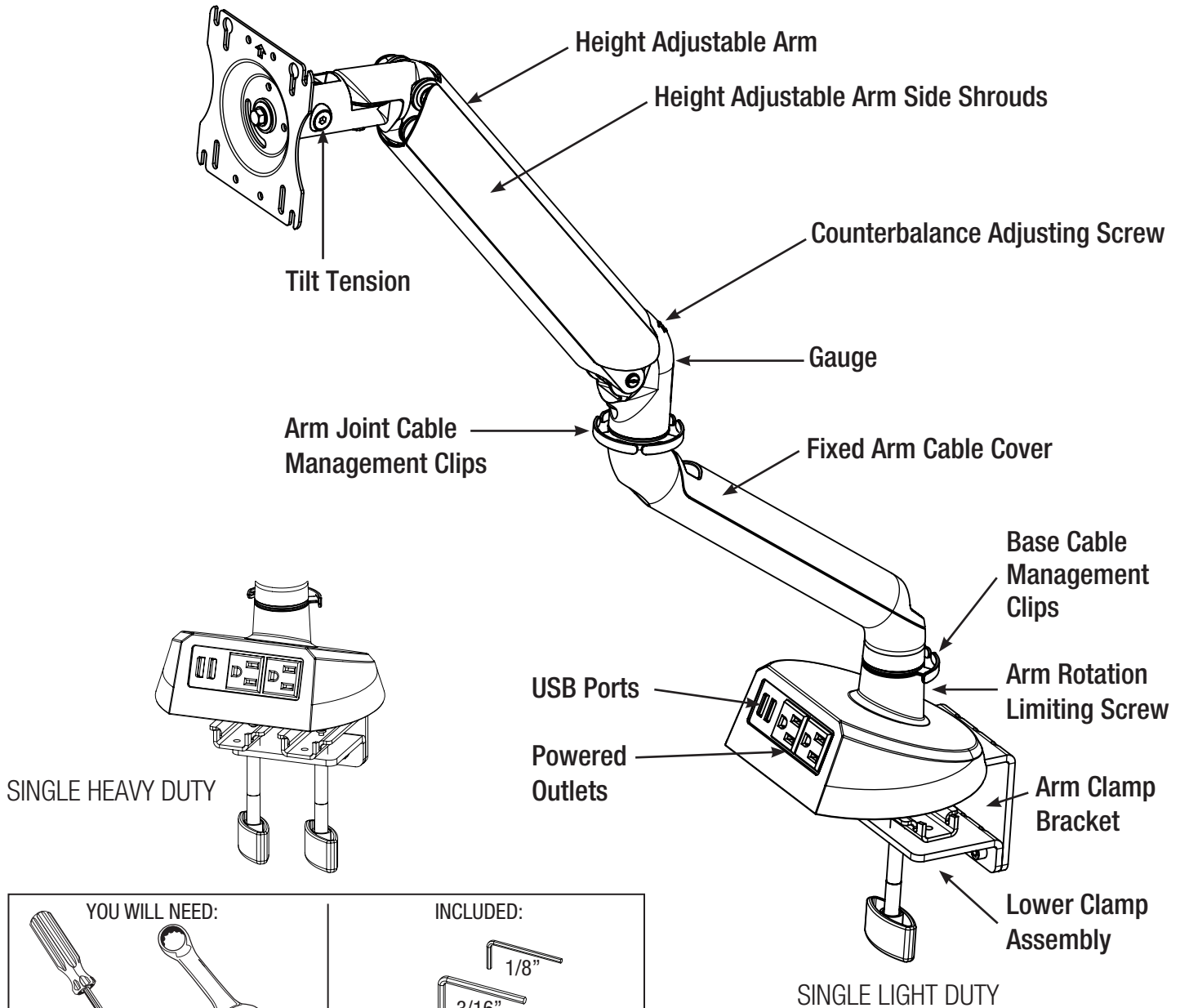

| | |
|--|--|
| <p>YOU WILL NEED:</p> <p>Phillips 9/16" Wrench</p> | <p>INCLUDED:</p> <p>1/8" 3/16" 1/4"</p> |
|--|--|

Grommet Plate - Bag Kit

Grommet Plate

3/8-16 x 2 1/2" Bolt

3/8-16 x 3 1/4" Bolt

Quick Connect Adapter - Bag Kit

QTY - 4
4MM x 8MM Long Screws

QTY - 4
4MM x 12MM Long Screws

INSTALLATION WARNINGS:

- Read the entire instruction manual before beginning any installation or assembly
- The installer must verify that the attachment surface can safely support the combined weight of all the attached equipment and hardware
- Improper installation of this equipment may cause extensive property damage or serious personal injury, either during or after installation

DISCLAIMER:

- The manufacturer and/or distributor will bear no responsibility for any damages of any kind arising from any improper installation of this product
- In no way will the manufacturer and/or distributor be held liable for any damage to the monitor, property or personal injury should any excessive force either intentionally or unintentional be applied to the monitor or monitor support assembly

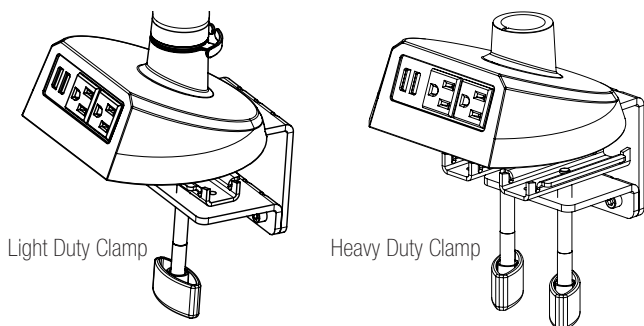

A. Clamp Mounting the Arm to the Work Surface (Light and Heavy Duty):

1. Open the clamp pad/s by unscrewing the clamping knob/s, so that the clamp assembly will slide onto the work surface
2. Position the arm assembly onto the work surface and securely clamp to the work surface by tightening the clamp knob/s

NOTE: For panel systems where the assembled clamp cannot be attached as an assembly. Remove the Lower Clamp Assembly by removing the three 1/4" socket head cap screws. Slide the arm clamp bracket in the space between the rear of the desk and panel system, then attach the Lower Clamp Assembly to the arm clamp bracket using the three 1/4 - 20 socket head cap screws. Tighten the clamp knob/s to securely clamp to the work surface.

B. Grommet Mounting the Arm to the Work Surface:

1. Remove the Arm Clamp Bracket by undoing the three 1/4" socket head cap screws.
2. Using a Phillips screw driver, remove the two countersunk screws which attach the arm clamp bracket to the base of the monitor arm
3. Lay any monitor cables through the grommet hole on the work surface
4. Align the base of the monitor arm assembly over the grommet hole on the work surface, passing any cables under the rear cut-out in the arm base
5. Depending on the thickness of the work surface insert either the 3/8-16 x 2 1/2" bolt or 3/8-16 x 3 1/4" bolt through the centre hole of the grommet plate, with the flanges facing up. Insert the threaded end of the 3/8" bolt through the grommet hole and into the threaded hole in the arm base & tighten securely with a 9/16" wrench or socket

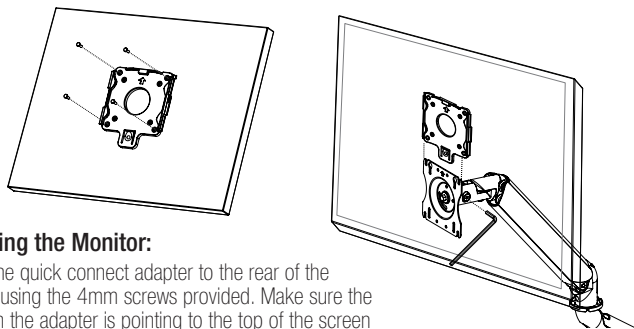

C. Mounting the Monitor:

1. Attach the quick connect adapter to the rear of the monitor using the 4mm screws provided. Make sure the arrow on the adapter is pointing to the top of the screen
2. With the arrow pointing up, slide the adapter bracket onto the arm VESA Plate until the bottom tab clicks onto the VESA plate
3. To remove the monitor, depress the tab to remove from the VESA bracket assembly

Adjusting the tilt tension:

If the monitor drops or is too tight, adjust the tilt tension screw at the side of the head using the 3/16" Allen key

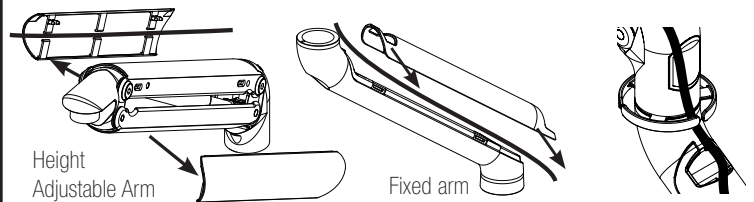

D. Base Cable Management - Pass the cables that extend from the rear of the desk through the two cable management clips situated between the base and fixed height arm

E. Fixed Arm Cable Management - Remove the fixed arm cable cover by pulling sideways to detach from the arm. Lay the cables into the trough on the cable cover and carefully re-attach the cover to the arm, then insert the cables into the cable clips at the arm joint

F. Height Adjustable Arm Cable Management - Pull to remove the left and right side cable shrouds and lay the cables into side shroud trough. Carefully replace the side shrouds ensuring the retaining clips are correctly seated. Ensure enough slack is provided in cables to provide full arm articulation

G. Primary Arm Counterbalance Adjustment:

1. With the monitor installed on the arm, locate the counterbalance adjusting screw
 2. If the adjustable arm lowers under the weight of the monitor, using the 1/4" Allen Key, turn the screw counter clockwise in the direction of the +arrow until balanced.
If the monitor is difficult to lower or lifts by itself, turn the adjustment screw clockwise in the direction of the - arrow, until the arm is counterbalanced.
- Note: Use the gauge at the rear of the arm to assist in setting up multiple arm installations

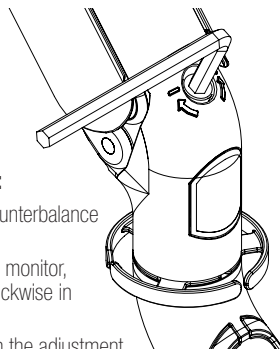

H. Secondary Counterbalance Adjustment:

If the monitors do not adjust smoothly or hold position after the primary adjustment method, further adjustment is available using the following procedure

1. Remove the right hand height adjustable arm shroud
2. Locate the two countersunk screw heads A & B
3. Using the 3/16" Allen Key, tighten the screws in 1/2 turn increments to fine tune the friction adjustment of the arm. Clockwise rotation will increase the friction on the joint and counterclockwise will decrease the friction. Both A & B screws should be adjusted equally
4. When the arm is counterbalanced to support the monitor load, replace the right hand height adjustable arm side shroud

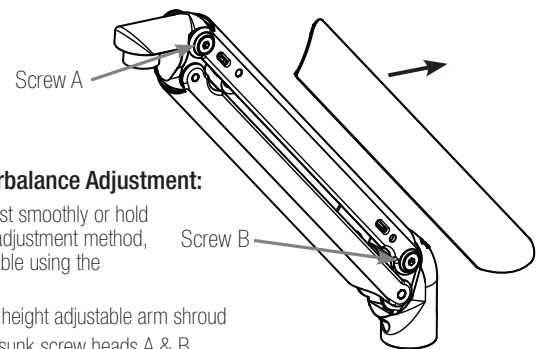

I. Rotation Limiter:

To limit the arm rotation to 180°, place the arm straight out towards the front edge of the work surface, locate the arm rotation limiting screw on the base & using the 1/8" Allen key tighten clockwise to engage lock. Do not over tighten

CAUTION: For total screen loads 20 lbs. or higher, the Rotation Limiter must be engaged to keep the load properly supported above the work surface.

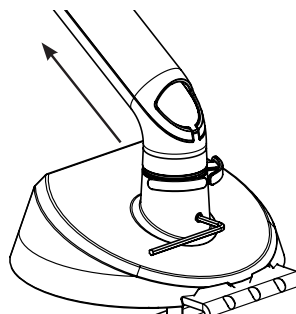

INSTALLATION MANUAL

Dual Screen Powered Base Monitor Support - Arm assembly

Dual (15-40 lbs capacity)

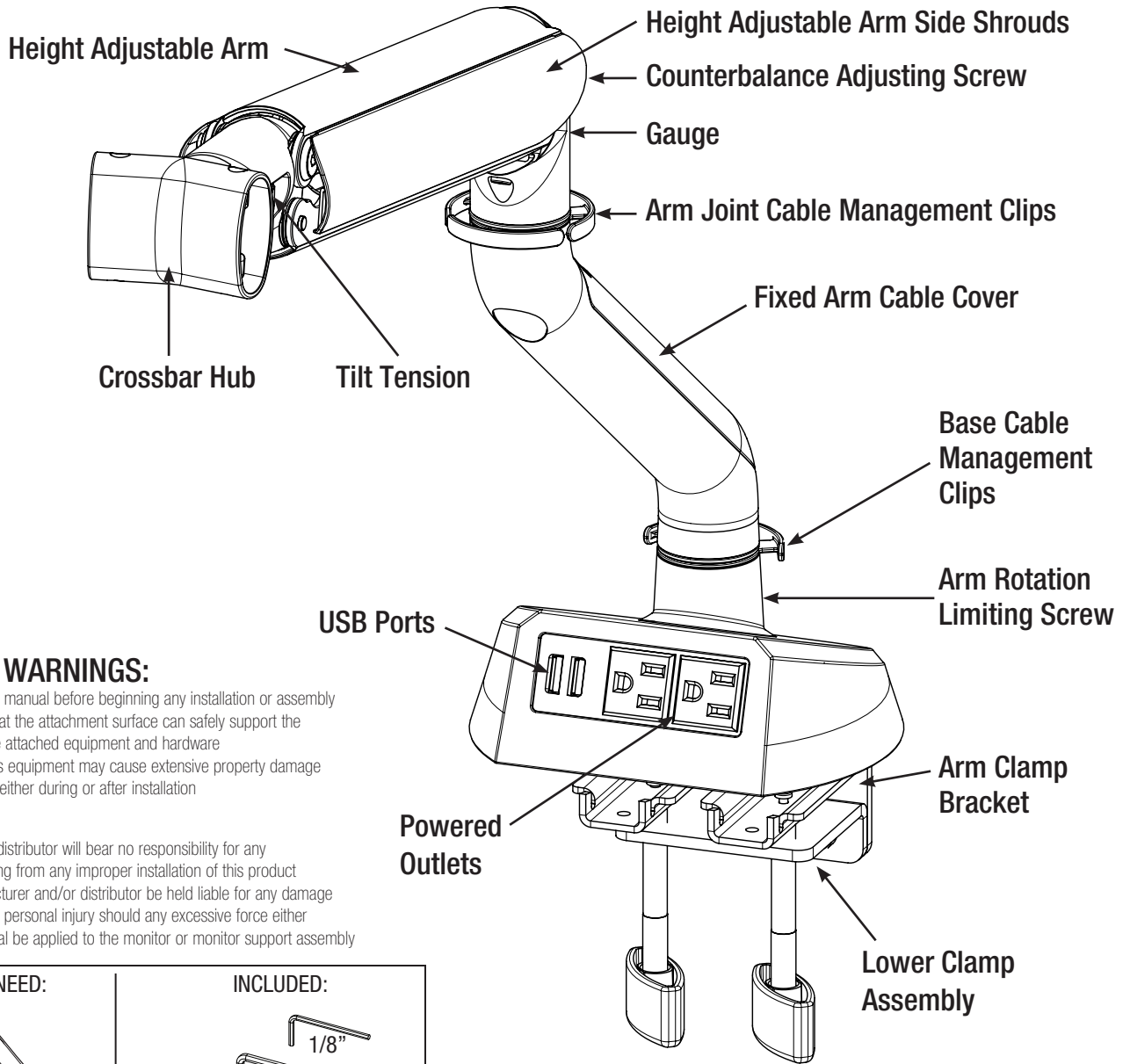

INSTALLATION WARNINGS:

- Read the entire instruction manual before beginning any installation or assembly
- The installer must verify that the attachment surface can safely support the combined weight of all the attached equipment and hardware
- Improper installation of this equipment may cause extensive property damage or serious personal injury, either during or after installation

DISCLAIMER:

- The manufacturer and/or distributor will bear no responsibility for any damages of any kind arising from any improper installation of this product
- In no way will the manufacturer and/or distributor be held liable for any damage to the monitor, property or personal injury should any excessive force either intentionally or unintentional be applied to the monitor or monitor support assembly

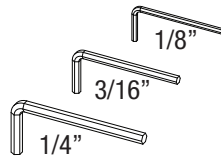
| YOU WILL NEED: | INCLUDED: |
|--|--|
|  <p>Phillips 9/16" Wrench</p> |  <p>1/8" 3/16" 1/4"</p> |

Grommet Plate - Bag Kit

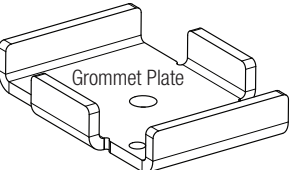

Grommet Plate

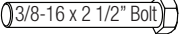

3/8-16 x 2 1/2" Bolt

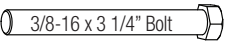

3/8-16 x 3 1/4" Bolt

Quick Connect Adapter - Bag Kit (2 supplied)



QTY - 4
4MM x 8MM Long Screws

QTY - 4
4MM x 12MM Long Screws

Left Hand Crossbar Assembly - Bag Kit

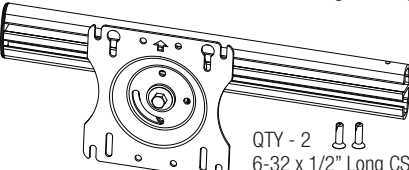

QTY - 2
6-32 x 1/2" Long CSK Screws

Right Hand Crossbar Assembly - Bag Kit

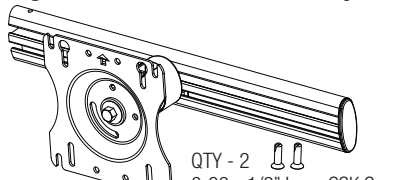

QTY - 2
6-32 x 1/2" Long CSK Screws

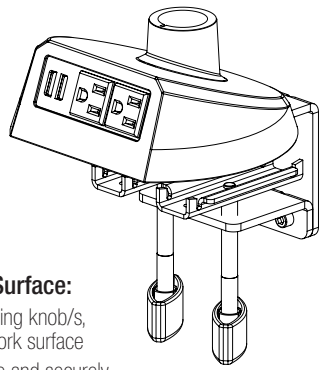

A. Clamp Mounting the Arm to the Work Surface:

1. Open the clamp pad/s by unscrewing the clamping knob/s, so that the clamp assembly will slide onto the work surface
2. Position the arm assembly onto the work surface and securely clamp to the work surface by tightening the clamp knob/s

NOTE: For panel systems where the assembled clamp cannot be attached as an assembly. Remove the Lower Clamp Assembly by removing the three 1/4" socket head cap screws. Slide the arm clamp bracket in the space between the rear of the desk and panel system, then attach the Lower Clamp Assembly to the arm clamp bracket using the three 1/4 - 20 socket head cap screws. Tighten the clamp knob/s to securely clamp to the work surface.

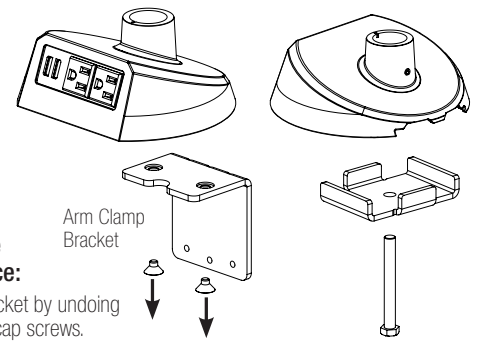

B. Grommet Mounting the Arm to the Work Surface:

1. Remove the Arm Clamp Bracket by undoing the three 1/4" socket head cap screws.
2. Using a Phillips screw driver, remove the two countersunk screws which attach the arm clamp bracket to the base of the monitor arm
3. Lay any monitor cables through the grommet hole on the work surface
4. Align the base of the monitor arm assembly over the grommet hole on the work surface, passing any cables under the rear cut-out in the arm base
5. Depending on the thickness of the work surface insert either the 3/8-16 x 2 1/2" bolt or 3/8-16 x 3 1/4" bolt through the centre hole in the grommet plate, with the flanges facing up. Insert the threaded end of the 3/8" bolt through the grommet hole and into the threaded hole in the arm base & tighten securely with a 9/16" wrench or socket

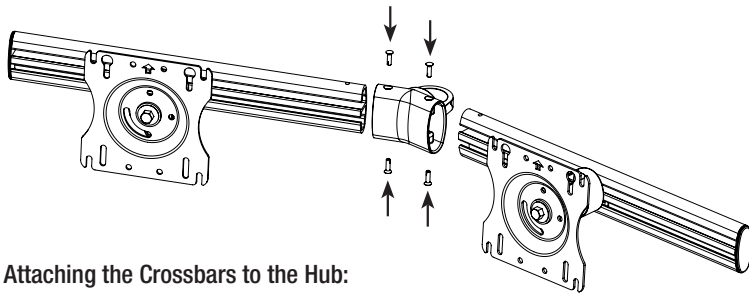

C. Attaching the Crossbars to the Hub:

1. Insert the left hand crossbar into the crossbar hub on the monitor arm
2. Insert the 6-32 x countersunk screws into the upper and lower mounting holes
3. Securely tighten the upper and lower screws using a Phillips screwdriver
4. Repeat the above procedure for the right hand crossbar

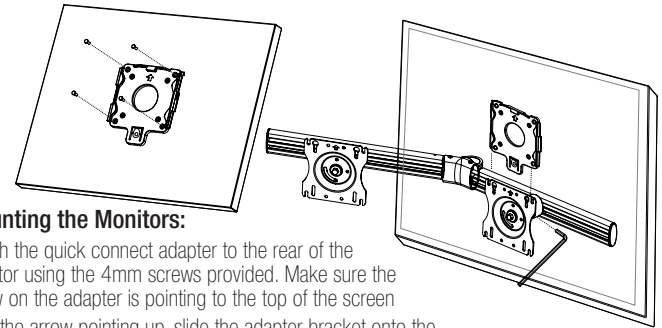

D. Mounting the Monitors:

1. Attach the quick connect adapter to the rear of the monitor using the 4mm screws provided. Make sure the arrow on the adapter is pointing to the top of the screen
2. With the arrow pointing up, slide the adapter bracket onto the arm VESA Plate until the bottom tab clicks onto the VESA plate
3. To remove the monitor, depress the tab to remove from the VESA bracket assembly

Adjusting the tilt tension:

If the monitor drops or is too tight, adjust the tilt tension screw at the side of the head using the 3/16" Allen key

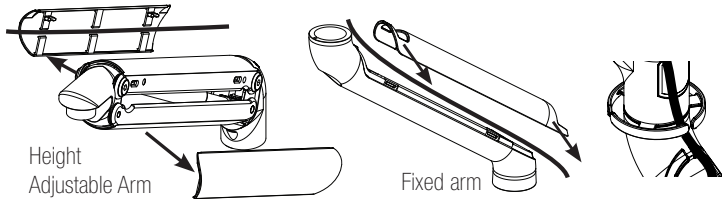

E. Base Cable Management - Pass the cables that extend from the rear of the desk through the two cable management clips situated between the base and fixed height arm

F. Fixed Arm Cable Management - Remove the fixed arm cable cover by pulling sideways to detach from the arm. Lay the cables into the trough on the cable cover and carefully re-attach the cover to the arm, then insert the cables into the cable clips at the arm joint

G. Height Adjustable Arm Cable Management - Pull to remove the left and right side cable shrouds and lay the cables into side shroud trough. Carefully replace the side shrouds ensuring the retaining clips are correctly seated. Ensure enough slack is provided in cables to provide full arm articulation

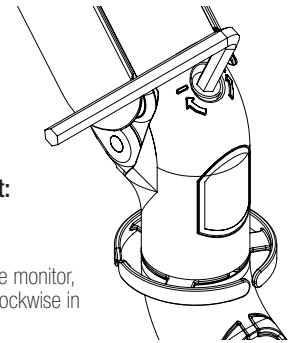

H. Primary Arm Counterbalance Adjustment:

1. With the monitors installed on the arm, locate the counterbalance adjusting screw
2. If the adjustable arm lowers under the weight of the monitor, using the 1/4" Allen Key, turn the screw counter clockwise in the direction of the + arrow until balanced.

If the monitor is difficult to lower or lifts by itself, turn the adjustment screw clockwise in the direction of the - arrow, until the arm is counterbalanced. Note: Use the gauge at the rear of the arm to assist in setting up multiple arm installations

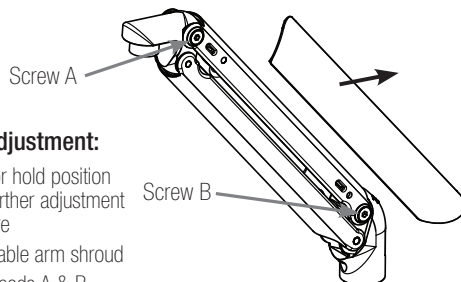

I. Secondary Counterbalance Adjustment:

If the monitors do not adjust smoothly or hold position after the primary adjustment method, further adjustment is available using the following procedure

1. Remove the right hand height adjustable arm shroud
2. Locate the two countersunk screw heads A & B
3. Using the 3/16" Allen Key, tighten the screws in 1/2 turn increments to fine tune the friction adjustment of the arm. Clockwise rotation will increase the friction on the joint and counterclockwise will decrease the friction. Both A & B screws should be adjusted equally
4. When the arm is counterbalanced to support the monitor load, replace the right hand height adjustable arm side shroud

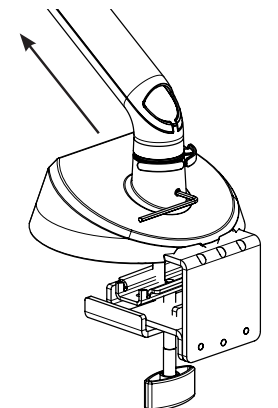

J. Rotation Limiter:

To limit the arm rotation to 180°, place the arm straight out towards the front edge of the work surface, locate the arm rotation limiting screw on the base & using the 1/8" Allen key tighten clockwise to engage lock. Do not over tighten

CAUTION: For total screen loads 20 lbs. or higher, the Rotation Limiter must be engaged to keep the load properly supported above the work surface.

King Cobra Monitor Slider Installation

STEP 1

Rotate the monitor mount on the existing arm 90° clockwise and lock out the rotation with the screw provided.

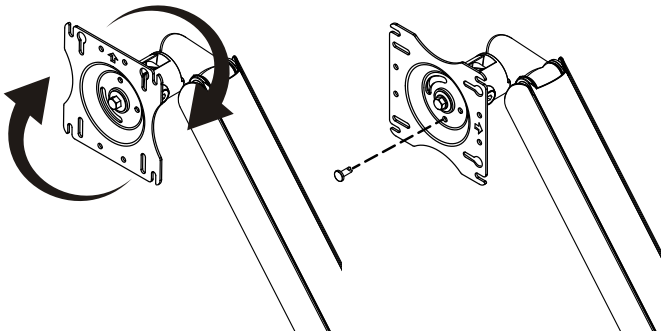

STEP 2

Using the 4 thumb knobs, install the slider to the monitor mount.

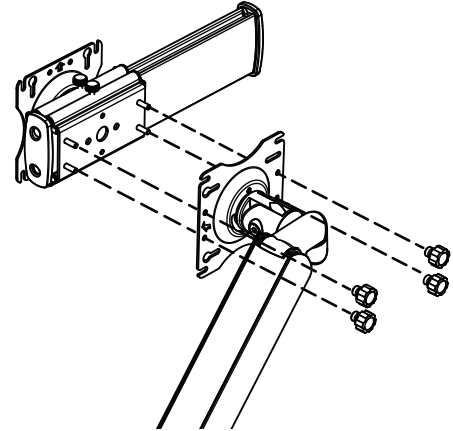

STEP 3

To slide the monitor left or right, loosen the 2 thumb knobs located at the top of the slider.

