

SitOnIt • Seating®

Parts List

- | | |
|---|--------------------------------|
| 2 | #10 x 32 Hex nut with washer |
| 8 | Washer |
| 4 | #8 x 1" panhead wood screws |
| 2 | #10 x 32 x 1/2" Machine screw. |
| 4 | 3/8" Spacer |
| 4 | 1/4" Spacer |

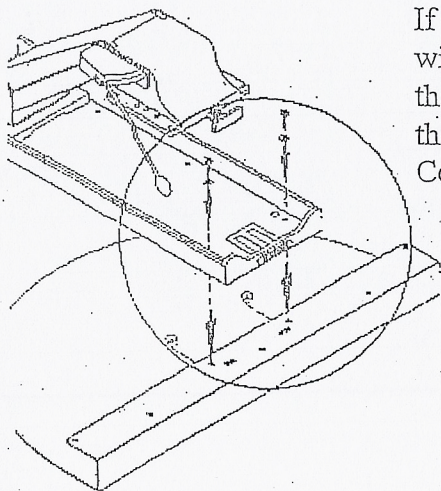

If the Corner maker is to be used with an adjustable keyboard arm, then it is recommended to attach the arm before mounting the Corner maker to the desk.

Using the supplied machine screws, 1 washer and the hex nut, attach the arm into the corresponding mounting holes and tighten.

2. INSTALL assembled unit to desk

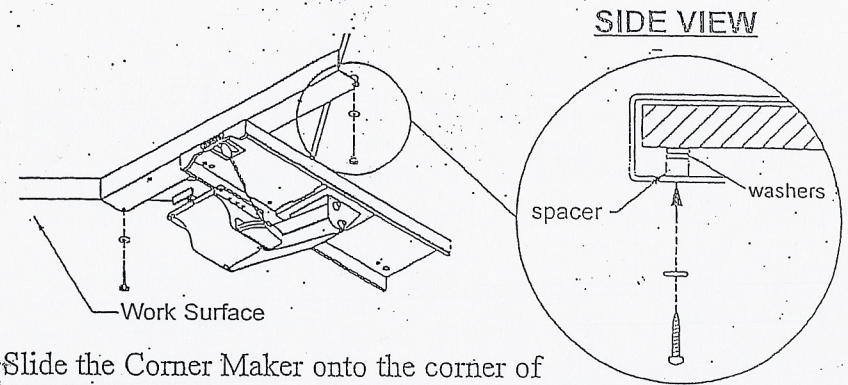

Slide the Corner Maker onto the corner of the work surface.

Use the appropriate number of spacers and washers to fill the space between the corner maker and the work surface as shown. Install One of the #8 x 1" wood screws in each corner.

NOTE: You must use the same combination of spacers and washers in the rear attachment points of the Keyboard Arm