

# HiQ

## HEIGHT-ADJUSTABLE BENCHING

### *Elevate your spaces—literally*

HiQ™ is our brand-new height-adjustable total benching solution. This collection lets you take productivity to a higher level with the push of a button, promoting healthier environments through essential ergonomics, connectivity and workspace division. And with a vast lineup of options and add-ons, there's no limit to how you can make it fit anywhere.

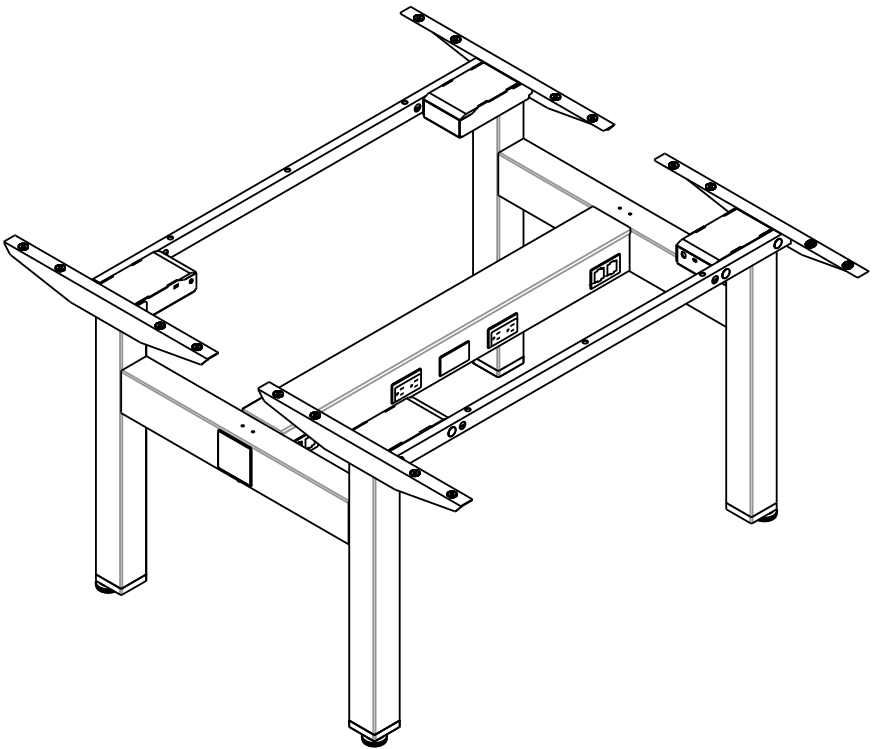

Read the entire instruction manual before you start installation and assembly. If you have any questions regarding any of the instructions or warnings, please contact your local distributor for assistance.

To report any issues with this product, contact our customer experience team at: (866) 764-4111 or [shopcx@sitonit.net](mailto:shopcx@sitonit.net).

## IMPORTANT SAFETY INSTRUCTIONS

---

**Read all instructions before using this product. Save these instructions.**

When using an electrical product, basic precautions should always be followed, including the following.

### **DANGER: TO REDUCE THE RISK OF ELECTRIC SHOCK**

#### **Use Care When Cleaning**

Always unplug this furnishing from the electrical outlet before cleaning. Follow all cleaning guidelines provided by the manufacturer.

## IMPORTANT SAFETY INSTRUCTIONS

---

**WARNING: TO REDUCE THE RISK OF BURNS, FIRE, ELECTRIC SHOCK, OR INJURY TO PERSONS:**

### Keep Dry and Use Care When Cleaning

Keep all electrical components away from water and humidity. Do not operate where aerosol (spray) products are being used or where oxygen is being administered.

Do not use outdoors. This equipment is approved for indoor use only.

### Do Not Modify

Use this product only for its intended use as described in these instructions. Do not use attachments not recommended by the manufacturer.

### Avoid Damage

Keep the cord away from heated surfaces. Unplug from outlet before putting on or taking off parts. To disconnect, turn all controls to the off position, then remove plug from outlet.

### Inspect Regularly

Never operate this product if it has a damaged cord or plug, if it is not working properly, if it has been dropped or damaged, or dropped into water. Return the product to a service center for examination and repair.

Inspect table system regularly and immediately stop using the product if it is damaged or has loose parts.

## IMPORTANT SAFETY INSTRUCTIONS

---



### **WARNING / AVERTISSEMENT**

#### **RISK OF INJURY / RISQUE DE BLESSURE**

Maximum load 220 lb including worksurface

*Charge maximale 220 lb incluant la surface de travail*



### **WARNING / AVERTISSEMENT**

#### **RISK OF FIRE AND SHOCK / RISQUE D'INCENDIE ET DE CHOC**

Use only min SJ type or equivalent, 18 AWG cord minimum

*Utilisez uniquement un type SJ minimum ou équivalent, cordon 18 AWG minimum*



### **WARNING / AVERTISSEMENT**

#### **RISK OF ELECTRIC SHOCK, FIRE, AND INJURY / RISQUE DE CHOC ÉLECTRIQUE, D'INCENDIE ET DE BLESSURE**

Review the assembly instructions to confirm that the appropriate critical components and accessories are being used with the furnishing

*Consultez les instructions d'assemblage pour confirmer que les composants et accessoires essentiels appropriés sont utilisés avec l'équipement*

## IMPORTANT SAFETY INSTRUCTIONS

---

### Servicing of Double-Insulated Products

In a double-insulated product, two systems of insulation are provided instead of grounding. No grounding means is provided on a double-insulated product, nor is a means for grounding to be added to the product. Servicing a double-insulated product requires extreme care and knowledge of the system and is to be done only by qualified service personnel. Replacement parts for a double-insulated product must be identical to the parts they replace. A double-insulated product is marked with the words “DOUBLE INSULATION” or “DOUBLE INSULATED”.



### **WARNING**

**RISK OF DEATH AND SERIOUS INJURY**

---

### Do Not Overload Table

Make sure the table system is not overloaded by the weight of the tabletop and objects on table. Evenly distribute load; excess loads near the edges can reduce stability and lead to tip-over. Do not exceed maximum load of 220 lb.

### Assemble With Care

Failure to follow instructions could result in product failure or potential injury. Keep fingers clear of pinch points

### Use Care to Keep the Table From Tipping Over

Before moving the table system, clear all objects and equipment from the table to reduce the risk of tipping over. Do not lift the table system by the tabletop. Adjust the table to its lowest height before moving. In order to avoid risk of tipping or collapse, make sure corded objects will not be pulled off the table or cause other objects to fall.

**WARNING****RISK OF DEATH AND SERIOUS INJURY****Clearance Around the Table**

Confirm that the surroundings on all sides of the table system are clear and make sure the power cord moves freely as table moves up and down. There should be at least **one inch** of clear space around the tabletop.

If the tabletop encounters resistance while moving, it will rebound.

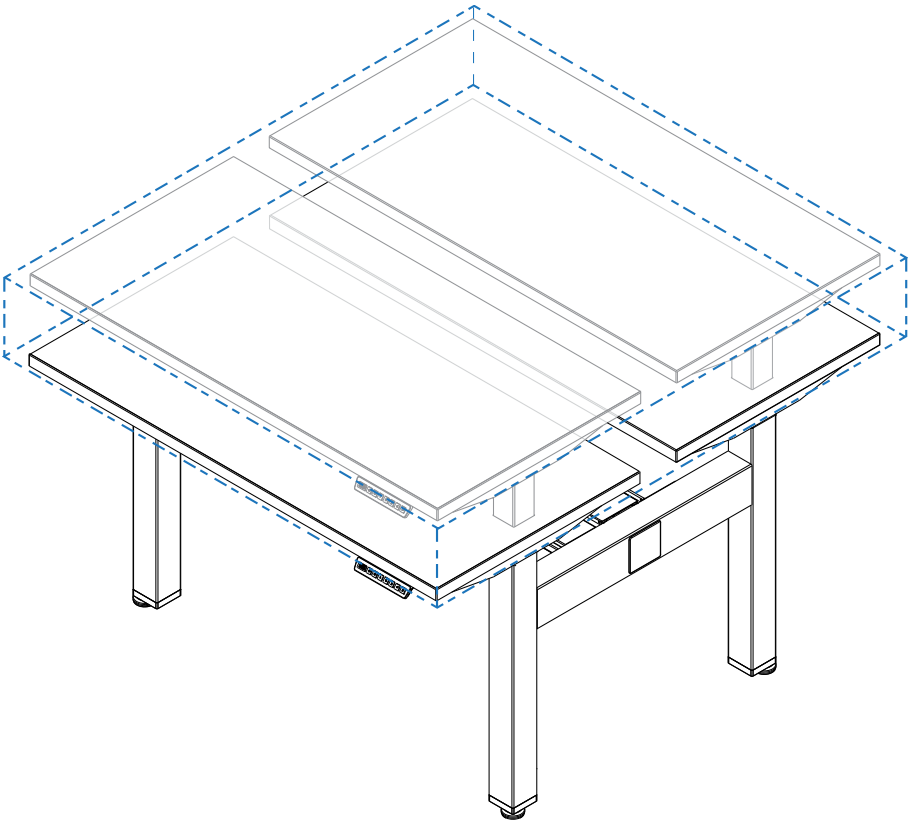

## Recommended Tools

---

- 6 mm Hex Key (Included)
- #2 Phillips Head Bit
- Cordless Drill/Driver

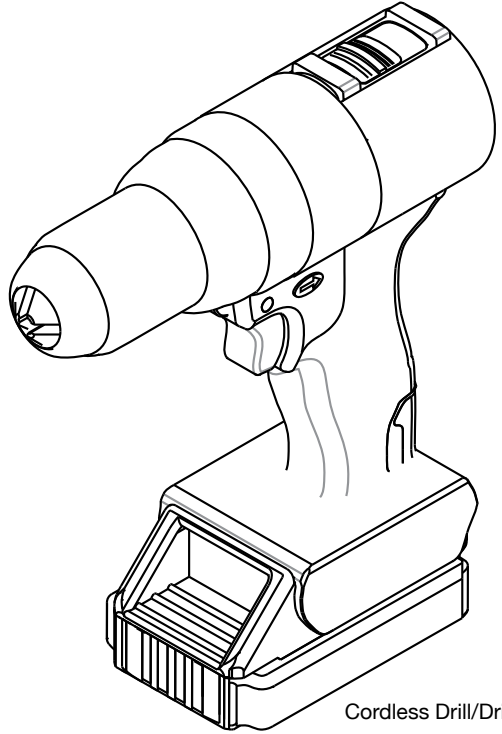

Cordless Drill/Driver

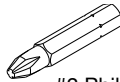

#2 Phillips Bit

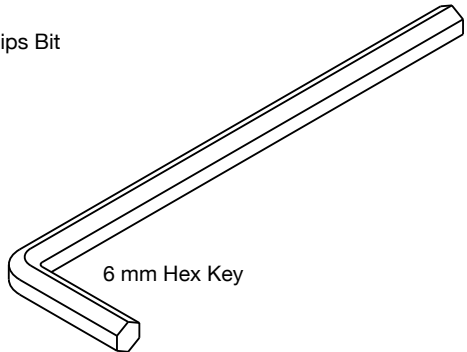

6 mm Hex Key

### Parts: HiQ Power Beam/Frame Kit

Part quantities for two back-to-back seats.

- Power Beam (1)
- Power Lid (1)
- Rail (2)
- Blank Faceplate (6)
- Data Faceplate (4)
- Data Adapter Tree (1)
- Bolt Cap (8)
- Ganger (1)
- Ganger Cover (1)
- Hardware:
  - M8 × 16 mm Screw (26)

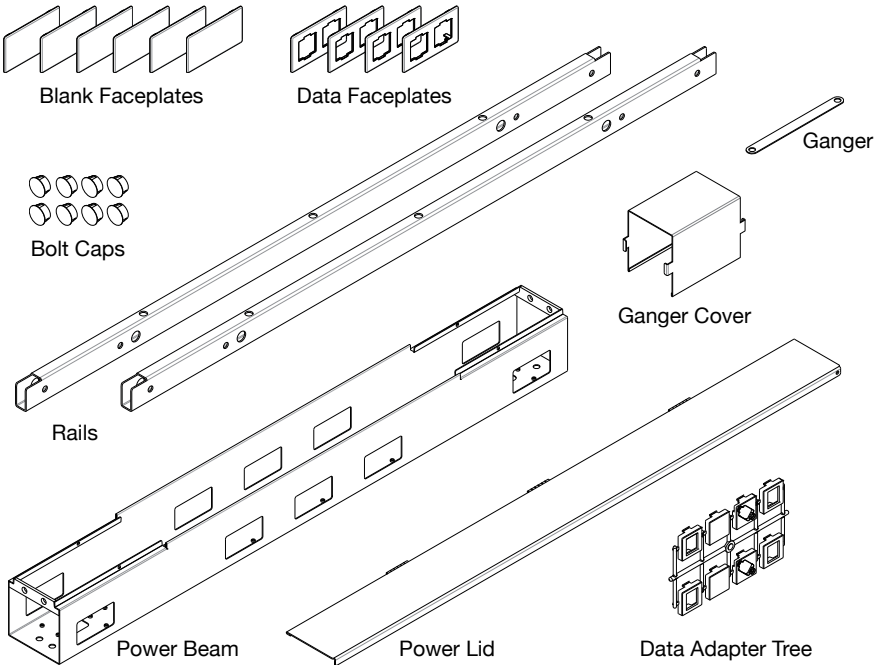

#### HARDWARE

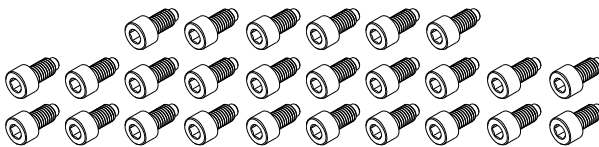

M8 × 16 mm Screws



## Parts: HiQ Column and End Pipe Kit

Part quantities for two back-to-back seats.

- Column (4)
- Top Support (4)
- Control Box (2)
- Extension Cord (2)
- Power Cord (2)
- Glide (4)
- Hardware:
  - #12 × ¾" Screws (24)
  - M4 × 16 mm Screw (14)

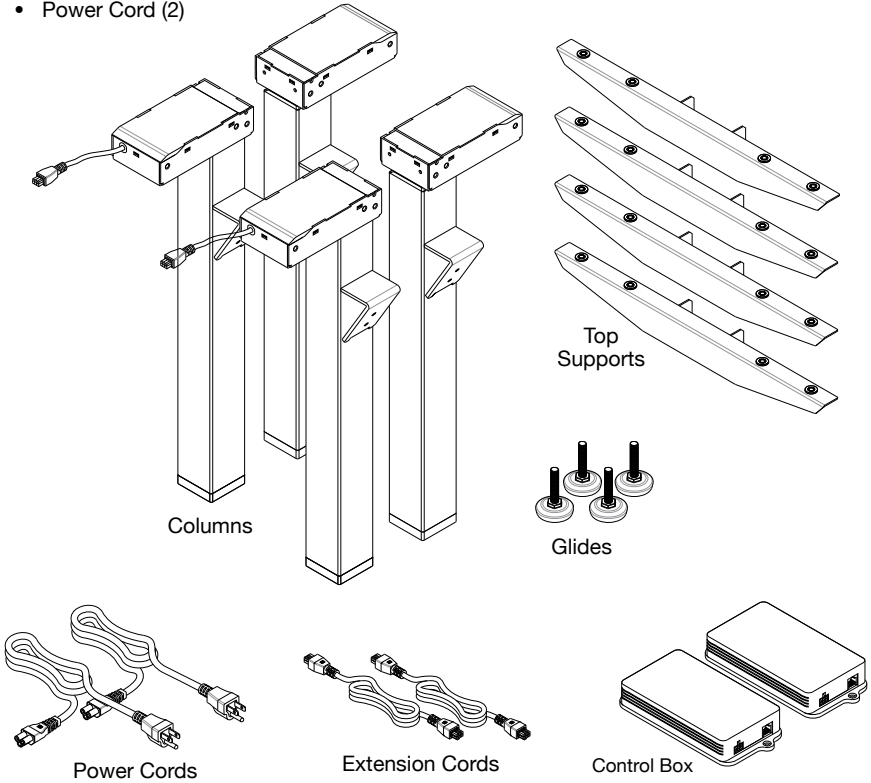

### HARDWARE



#12 × ¾" Screws



M4 × 16 mm Screw

### Parts: HiQ Crossbeam Kit

Part quantities for two back-to-back seats.

- Crossbeam (2)
- End Cover (2)
- Hardware:
  - M8 × 16 mm Screw (8)

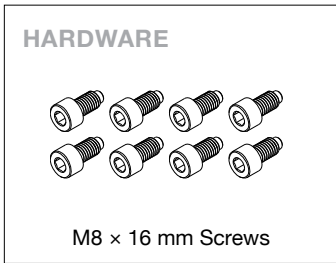
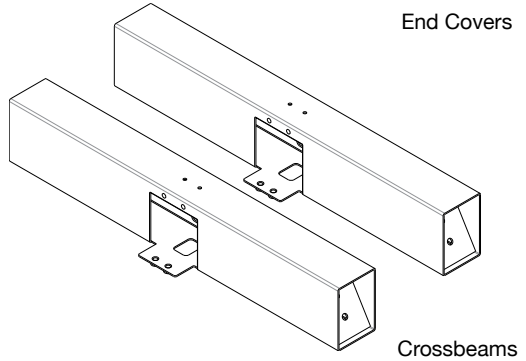
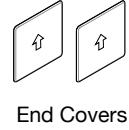

### Parts: HiQ Trough Kit

Part quantities for two back-to-back seats.

- Cable Trough (2)
- Hardware:
  - M8 × 16 mm Screw (4)

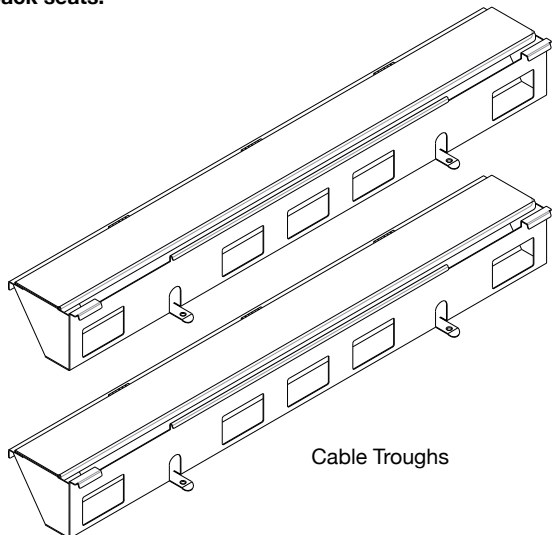
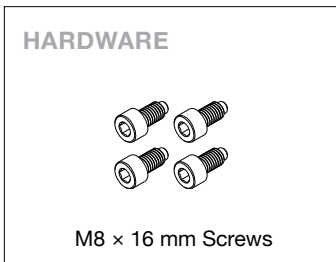

## Parts: HiQ End Panel Kit

Part quantities for two back-to-back seats.

- End Panel (2)
- Hardware:
  - M8 × 16 mm Screw (4)

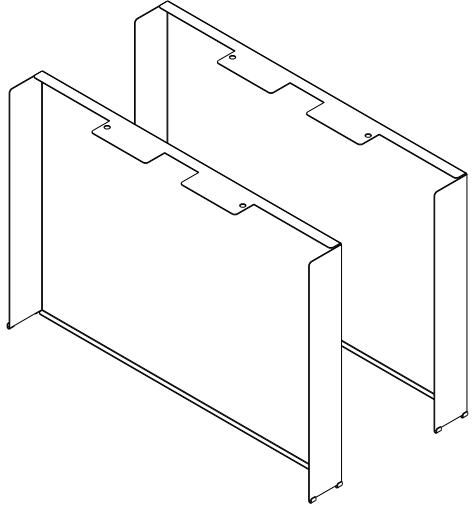
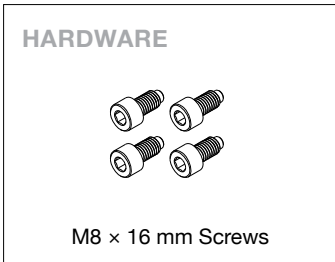

## Parts: Wire Management, Cable Carrier Assembly

Part quantities for two back-to-back seats.

- Wire Manager (2)
- Hardware:
  - 3/16" Screw (8)

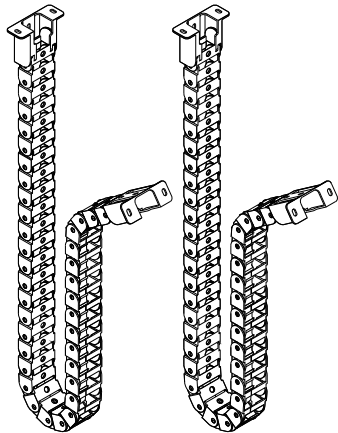
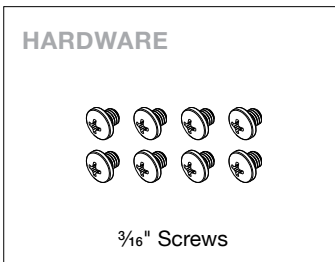

Wire Manager

## Parts: Packaged Separately

### Part quantities for two back-to-back seats.

- Power Harness (1)
- Power Infeed (1)
- Jumper (1)
- Hand Control (2)
- Bench Top (2)
- Power Receptacle (4-6)
- **Hardware:**
  - Hose Clamp (1)
  - #10 × 3/16" Screw (1)

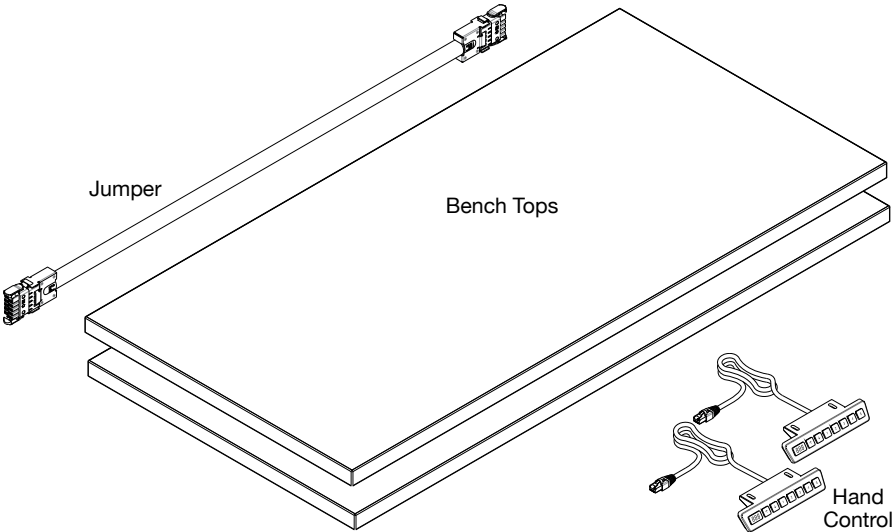
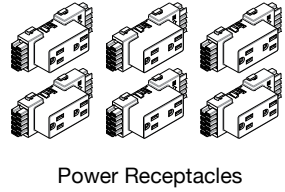
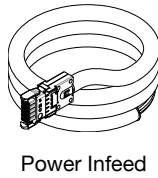
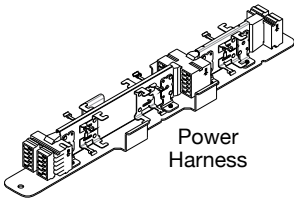

### HARDWARE

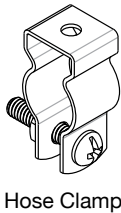

**Step 1:** Create an I-frame assembly with the power beam and crossbeams.

**CAUTION:** Protect the floor so the M8 screws don't scratch the it.

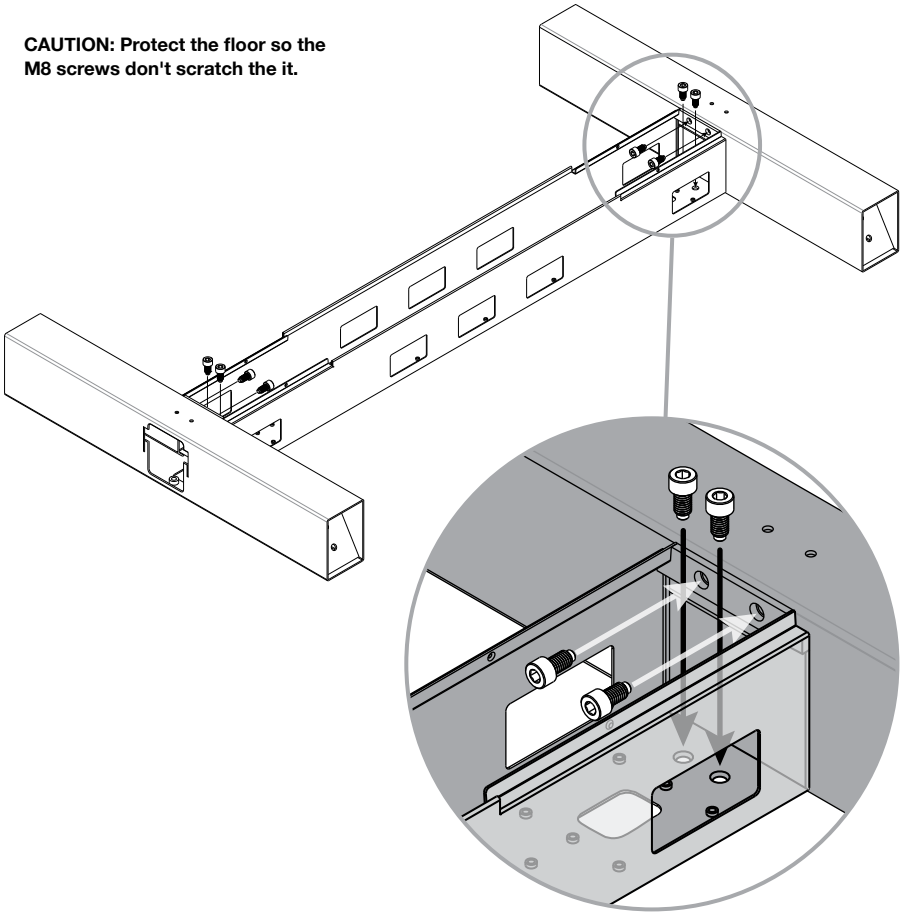

### 1:1 HARDWARE

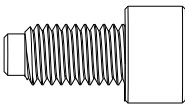

M8 x 16 mm Screw

### TOOLS



M6 mm Hex L-key

**Step 2:** Screw the glides into the columns

---

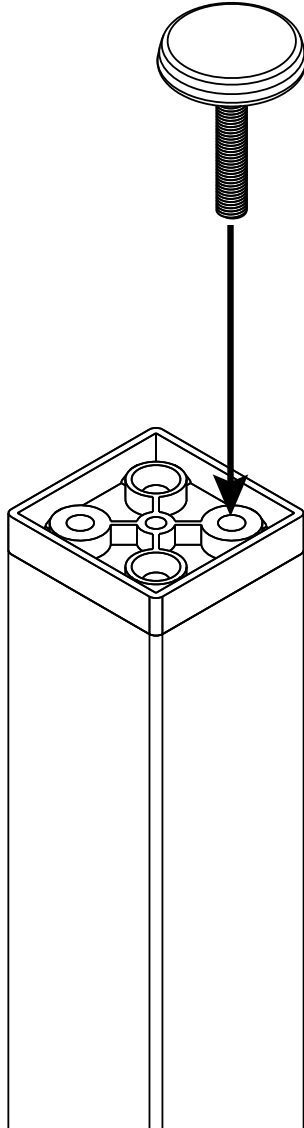

**Step 3:** Flip the I-frame assembly and slide the columns into the crossbeams.

---

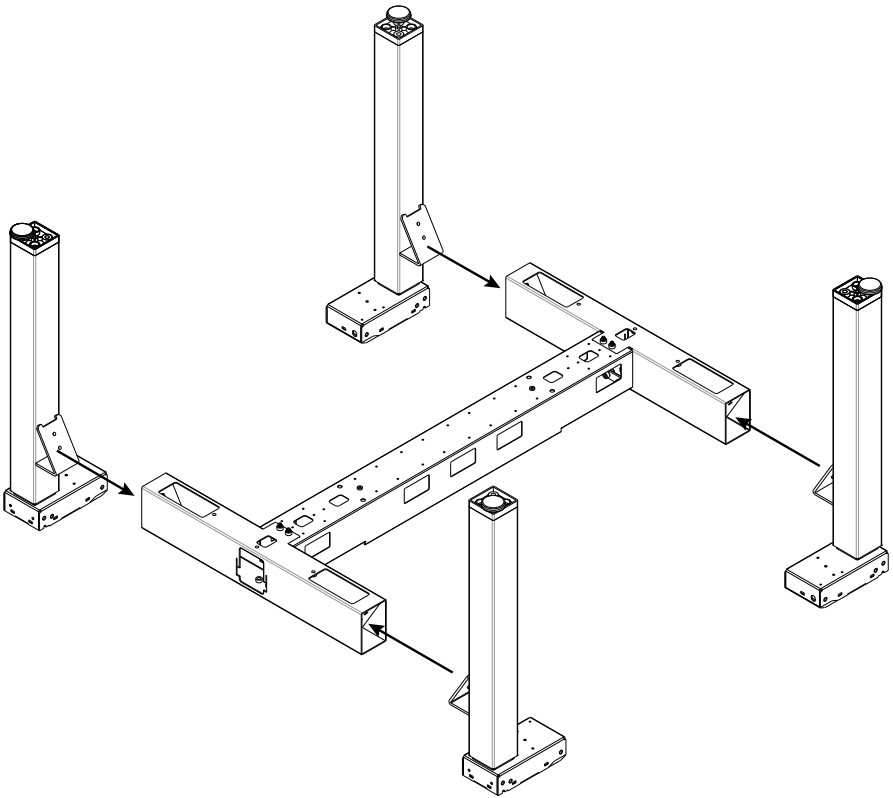

**Step 4:** Attach the columns, ensuring the motor housings face inward.

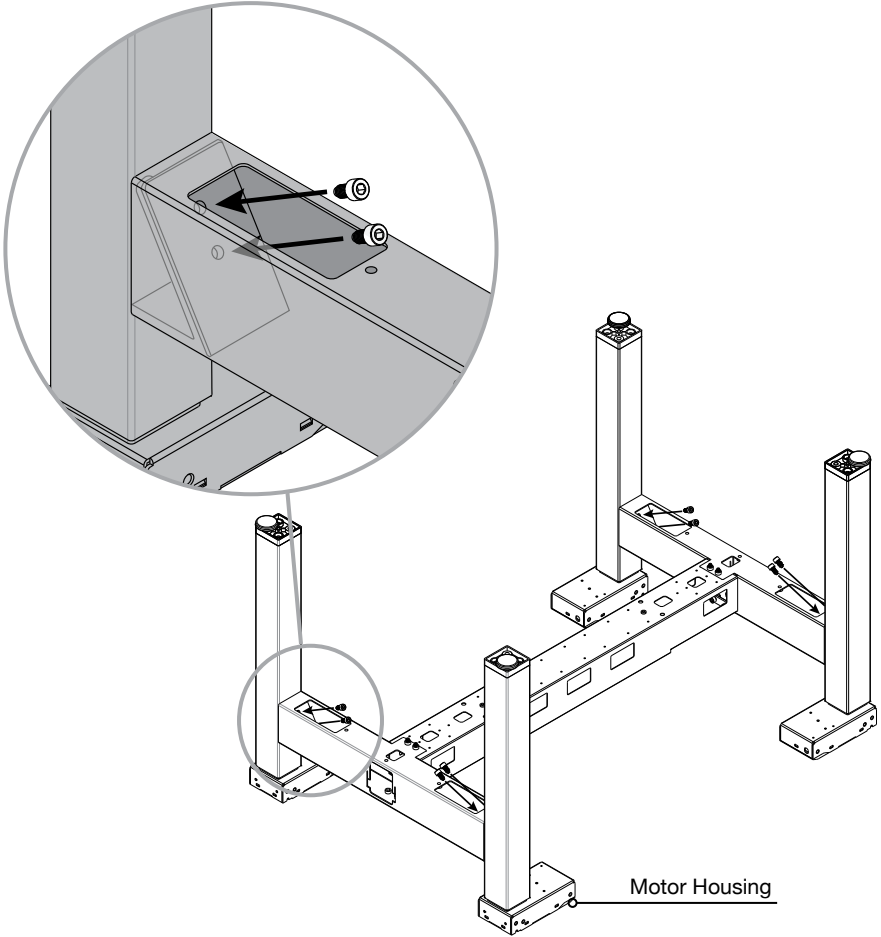

### 1:1 HARDWARE

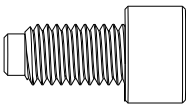

M8 x 16 mm Screw

### TOOLS



M6 mm Hex L-key



**Step 5:** Attach an end panel to each end of the bench line. You will need to plan ahead if you are ganging together multiple benches.

If optional end panels were not purchased, continue to step 6.

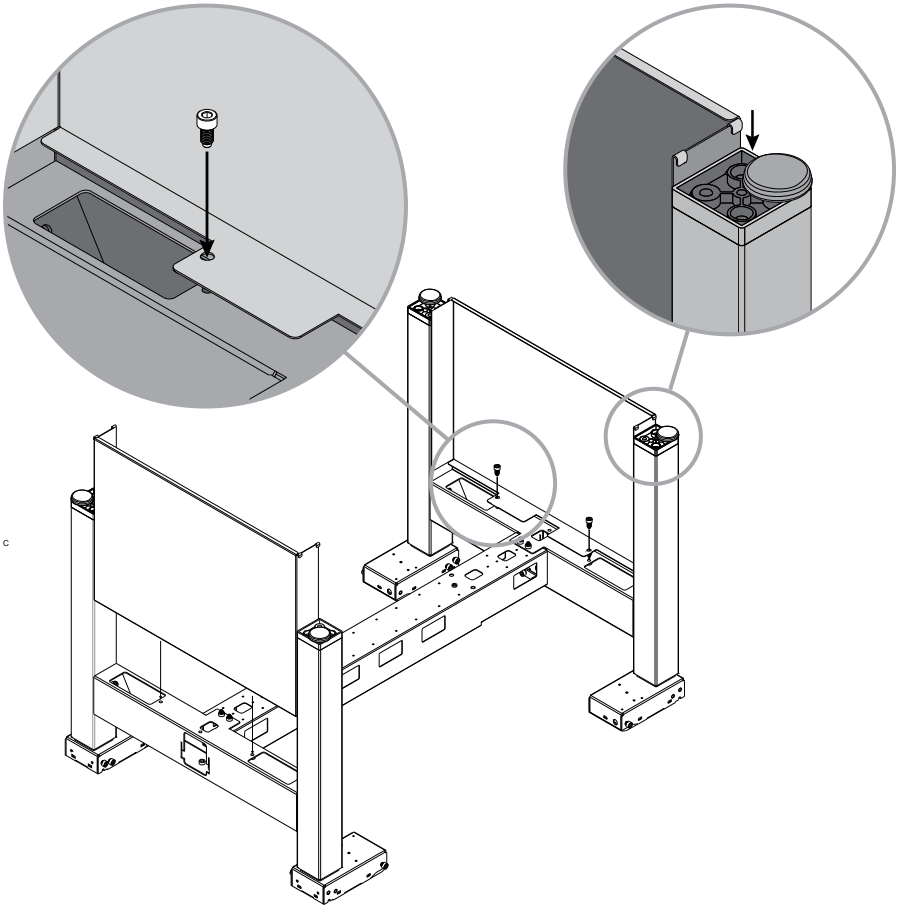

### 1:1 HARDWARE

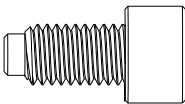

M8 x 16 mm Screw

### TOOLS



M6 mm Hex L-key

**Step 6:** Carefully flip the partially finished bench and attach the rails.

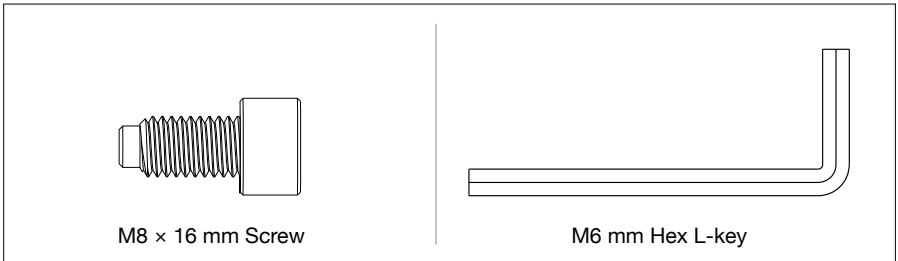
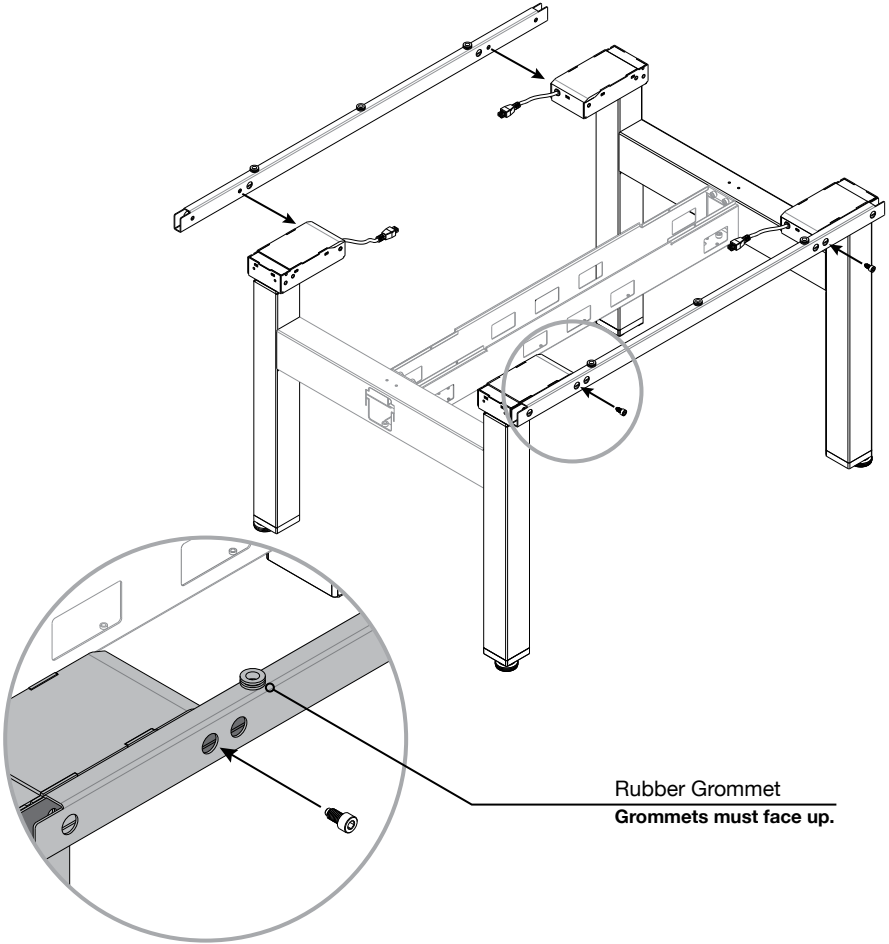

### Step 7: Attach the top supports.

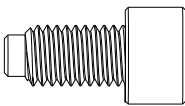
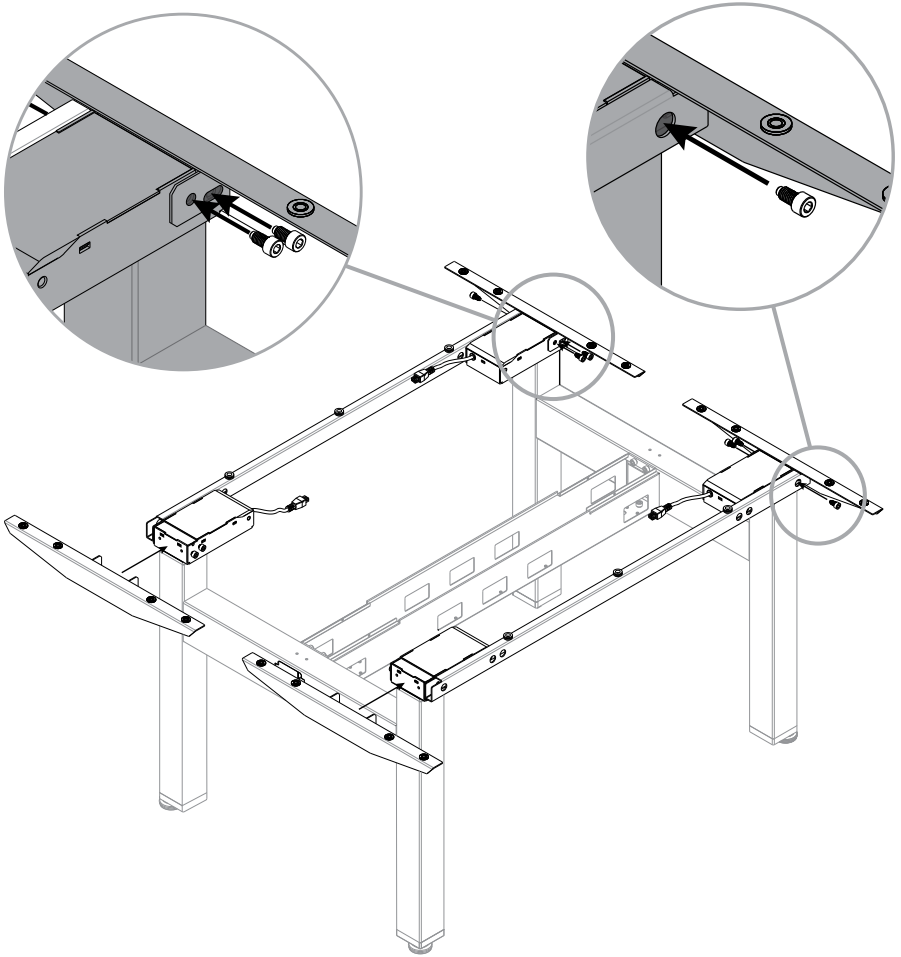

M8 × 16 mm Screw



M6 mm Hex L-key

**Step 8:** Hook the cable trough onto the power beam.

If optional cable trough was not purchased, continue to step 10.

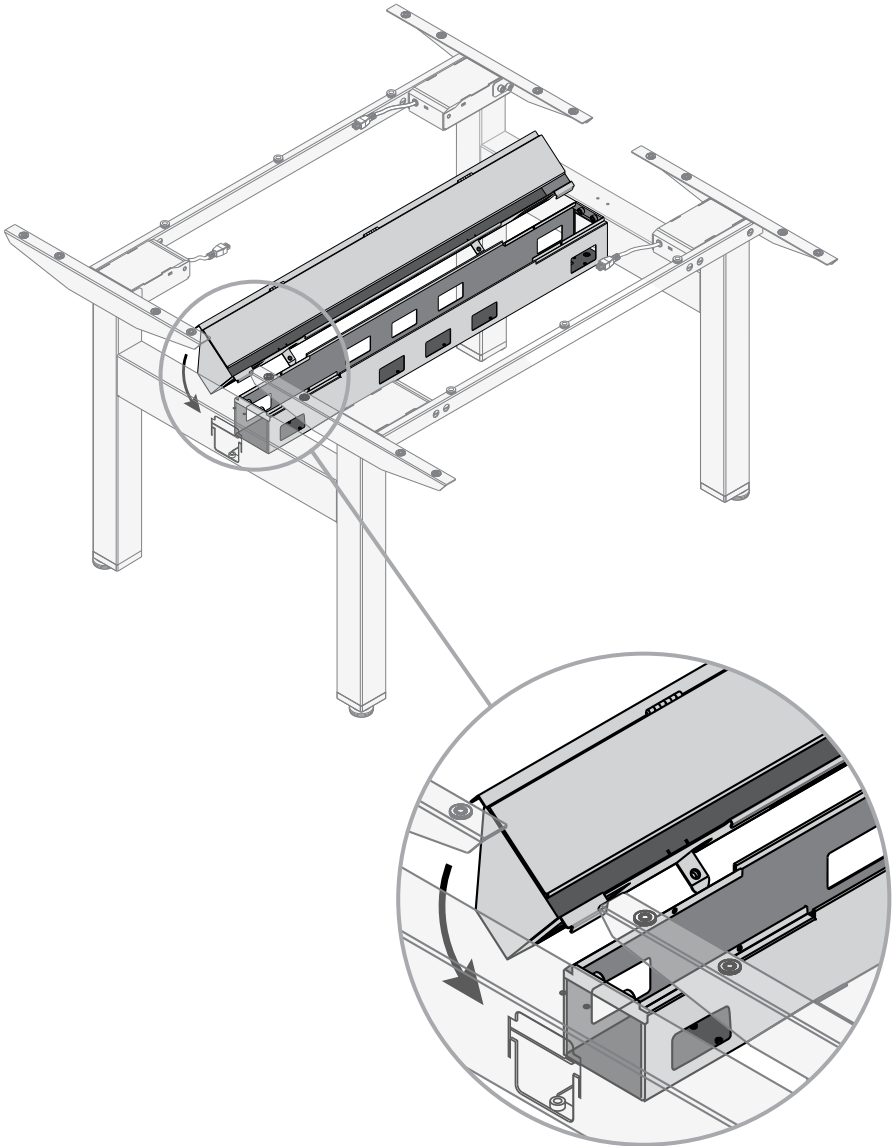

**Step 9:** Screw through the power beam and into the tabs on the bottom of the trough.

---

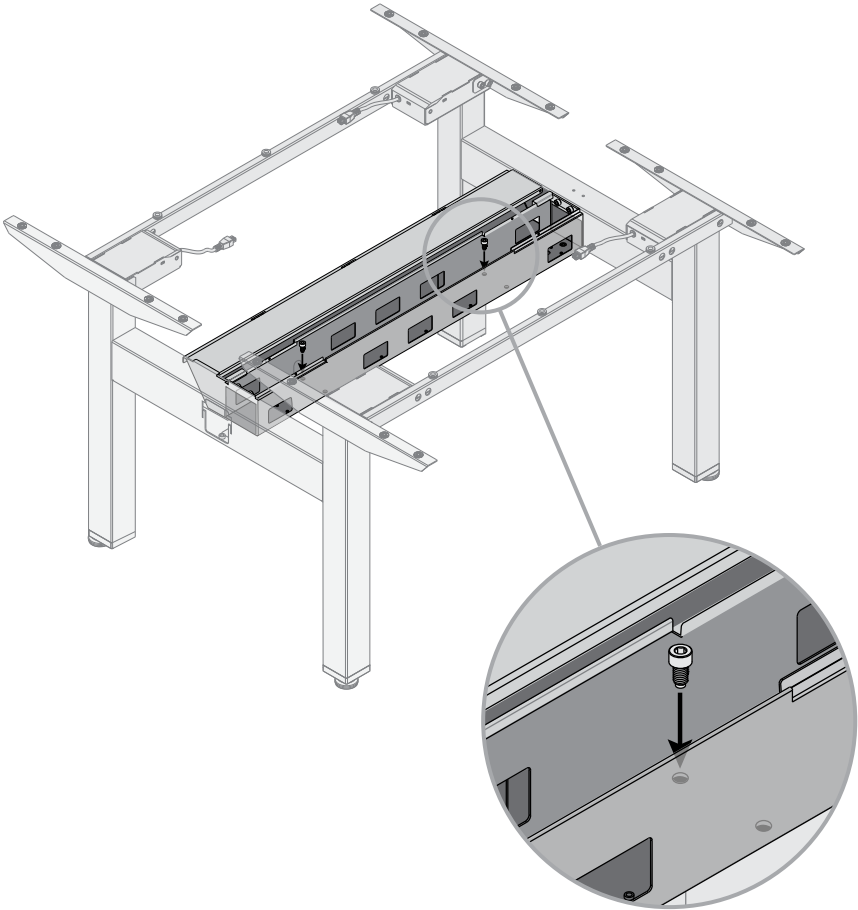

### 1:1 HARDWARE

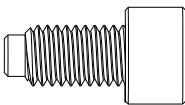

M8 × 16 mm Screw

### TOOLS

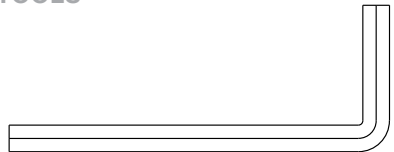

M6 mm Hex L-key

**Step 10:** Insert the power receptacles into the power harness.

---

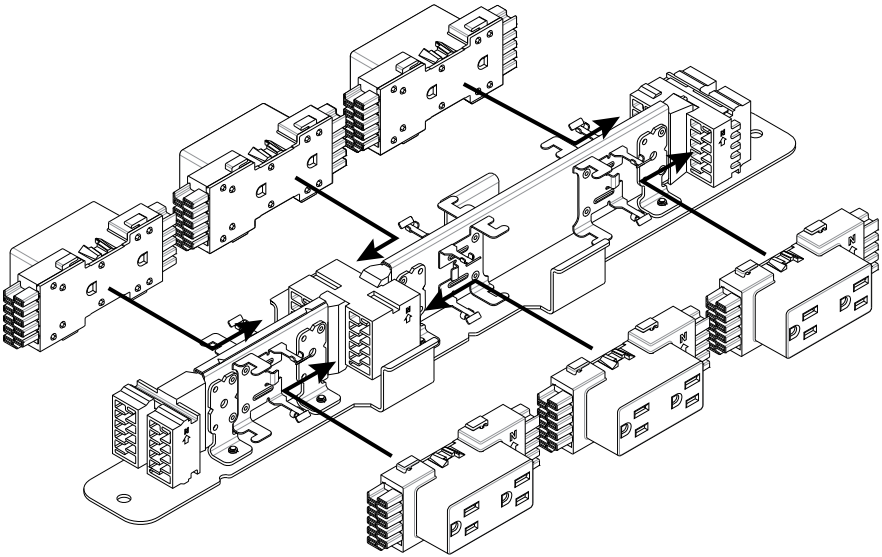

**Step 11:** Insert the power harness into the power beam and attach it to the bottom of the beam.

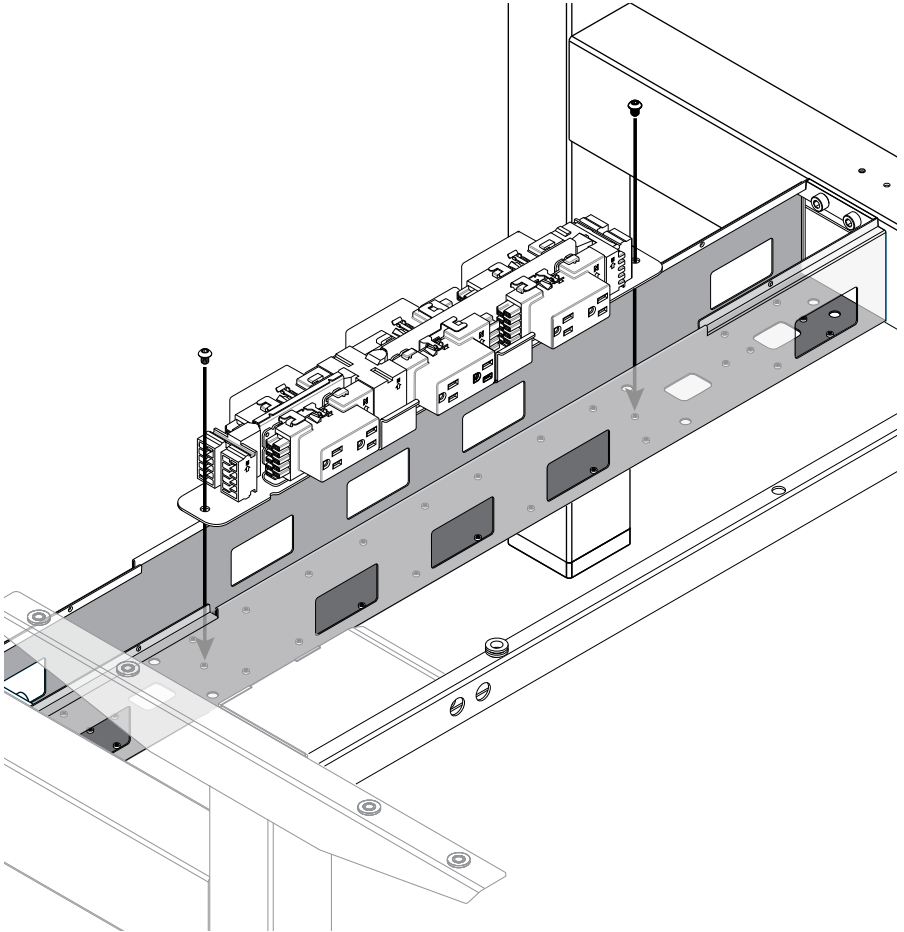

### 1:1 HARDWARE



M6 x 8 mm Screw

### TOOLS

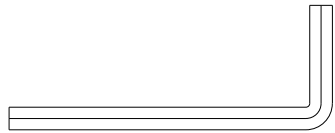

M5 mm Hex L-key

**Step 12:** Detach the screw and nut from the hose clamp. Set them aside.

---

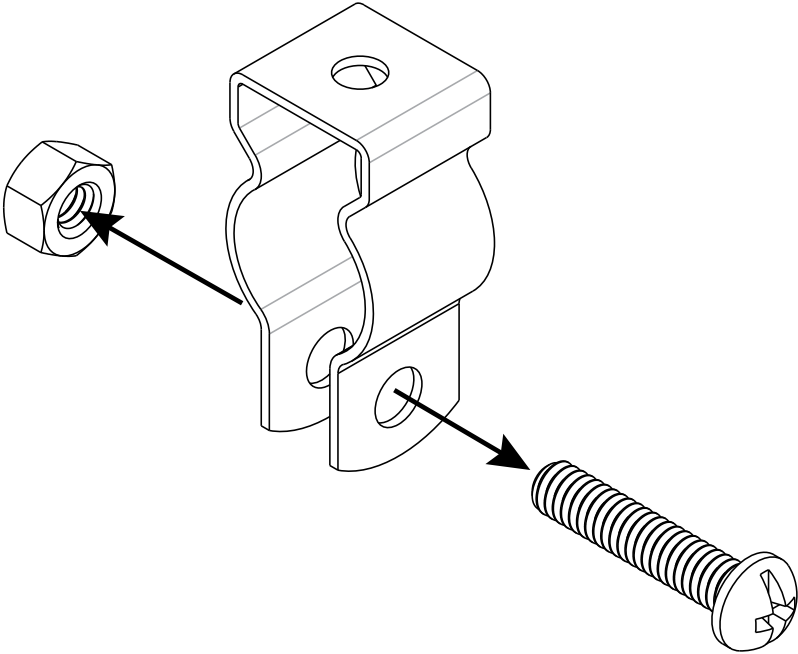



**Step 13:** Attach the hose clamp to the inside of the power beam.

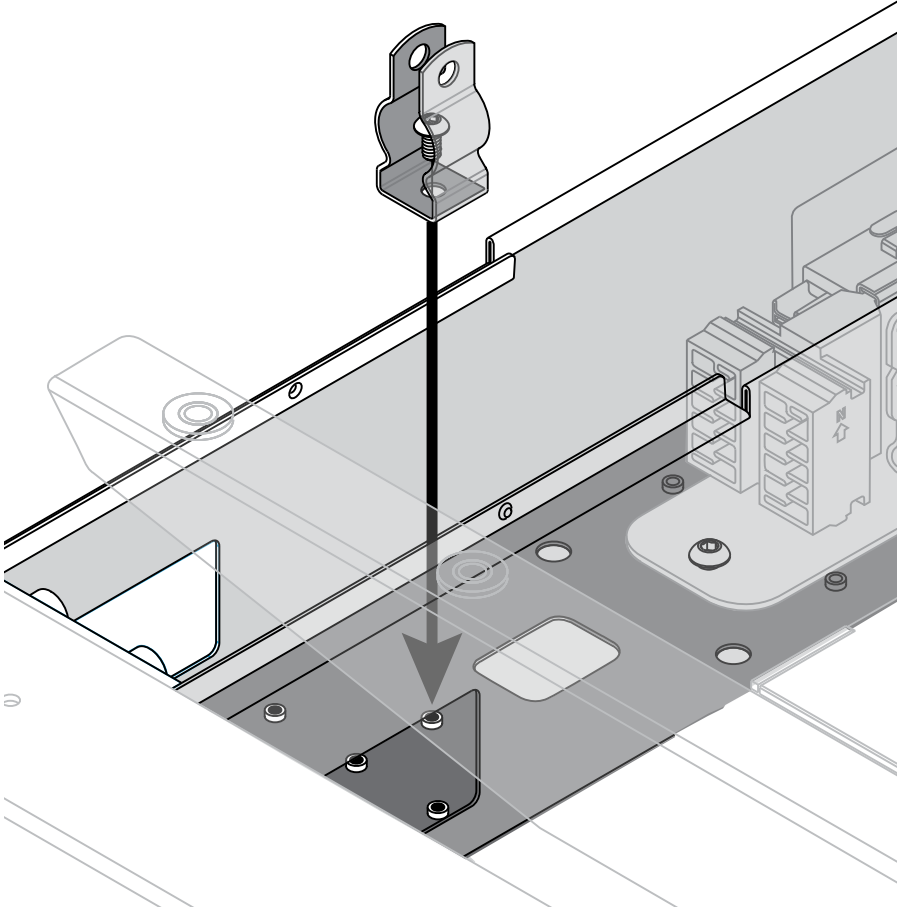

**1:1 HARDWARE**



#10 x 3/16" Screw

**TOOLS**

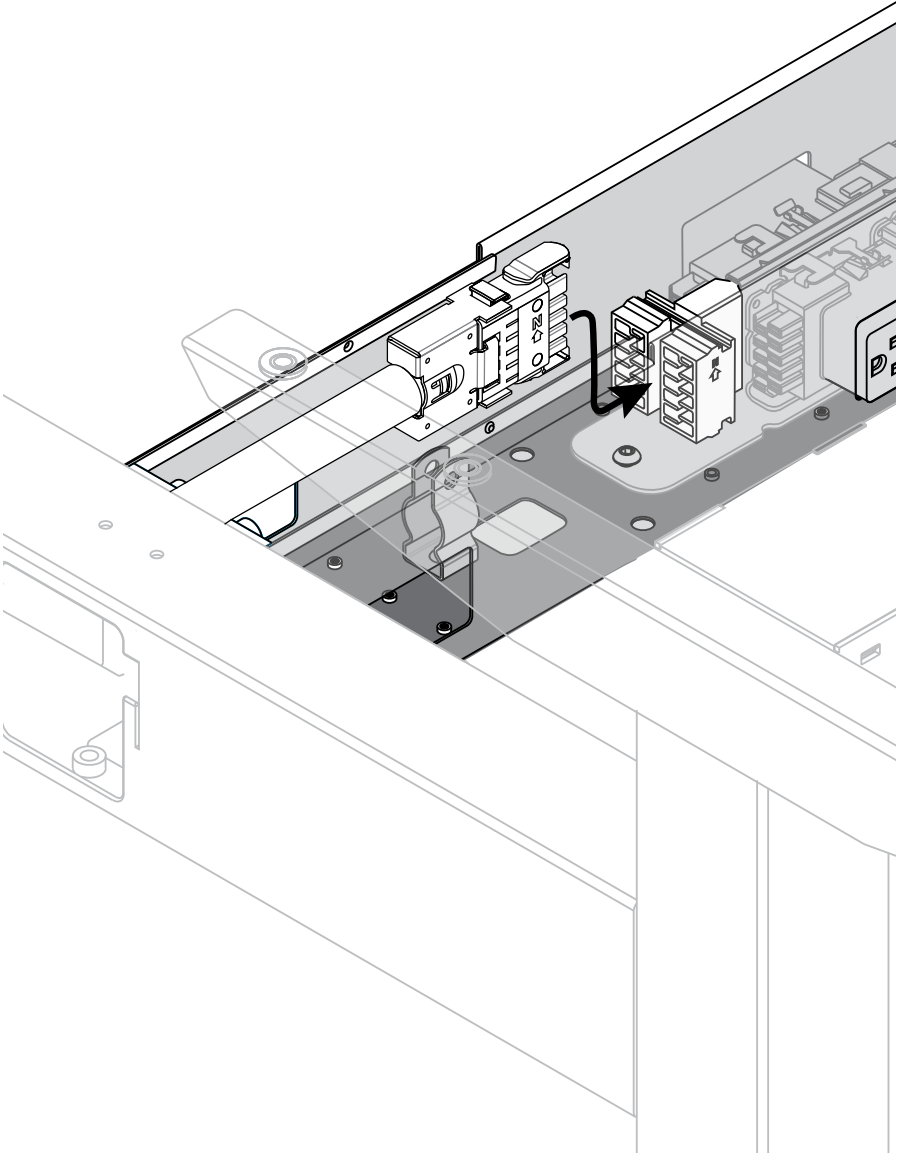

1/8" Hex L-key

**Step 14:** Plug the infeed into the power harness

**Step 15:** Route the infeed through the crossbeam and down the leg before closing the hose clamp with the reserved screw and nut.

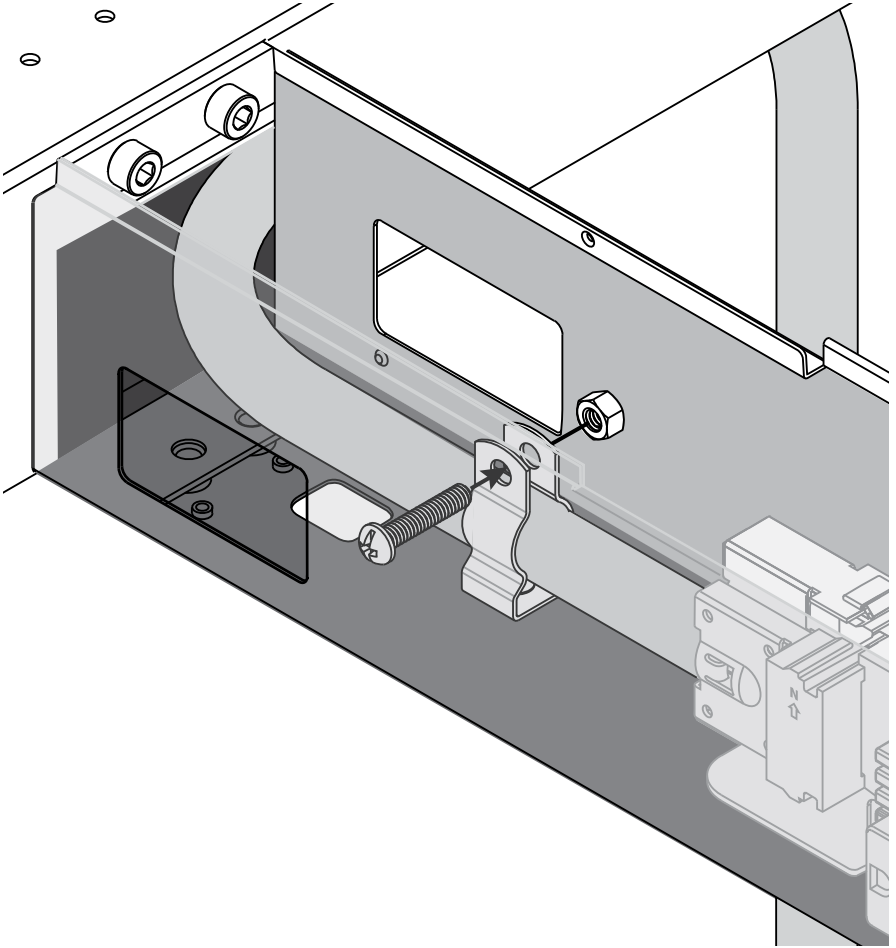

### 1:1 HARDWARE

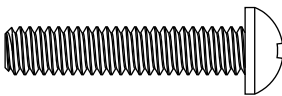

1/4 x 1 1/4" Screw

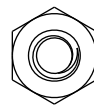

1/4" Nut

**Step 16:** Plug the jumper into the infeeds of the two beams, passing the jumper through the hole in the crossbeams.

If installing a 2-seat unit skip these ganging steps and continue to step 19.

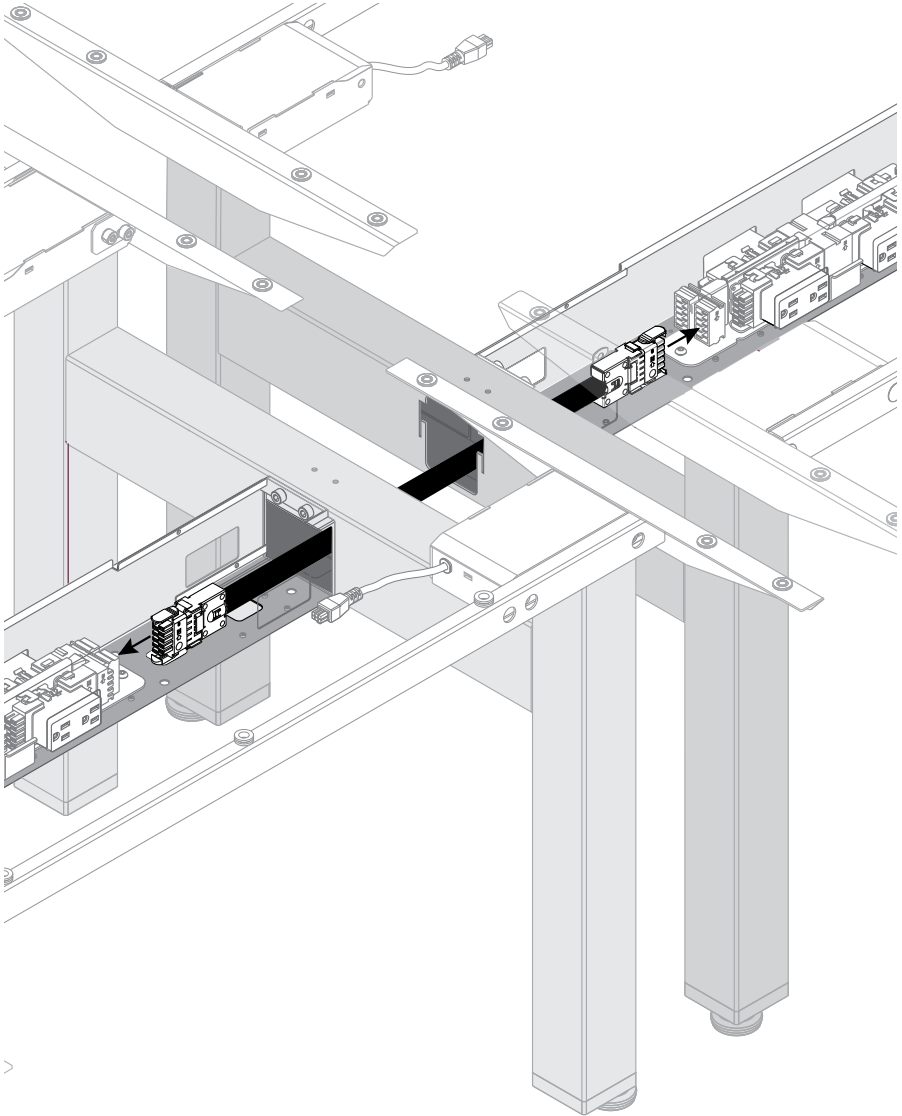

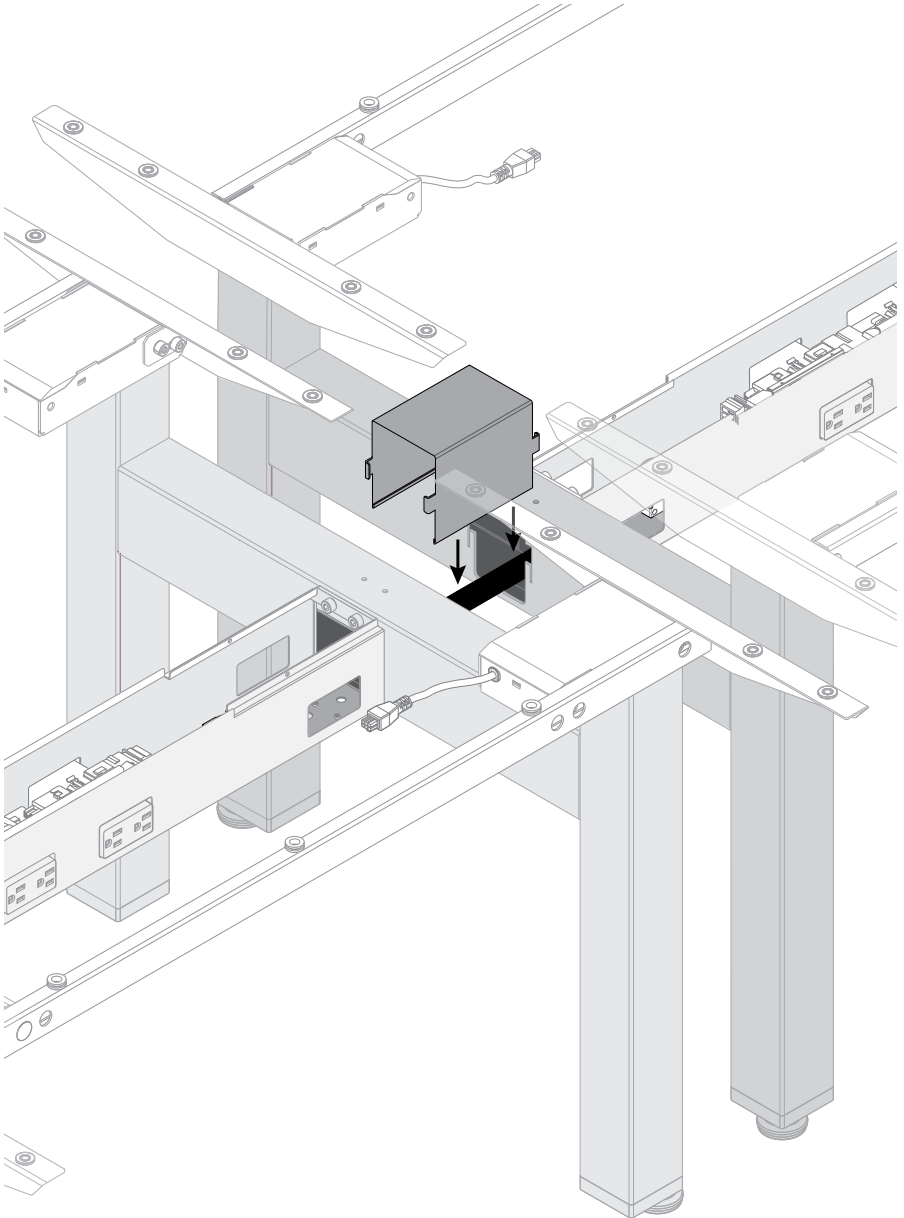
**Step 17:** Attach the ganger cover.

### Step 18: Attach the ganger.

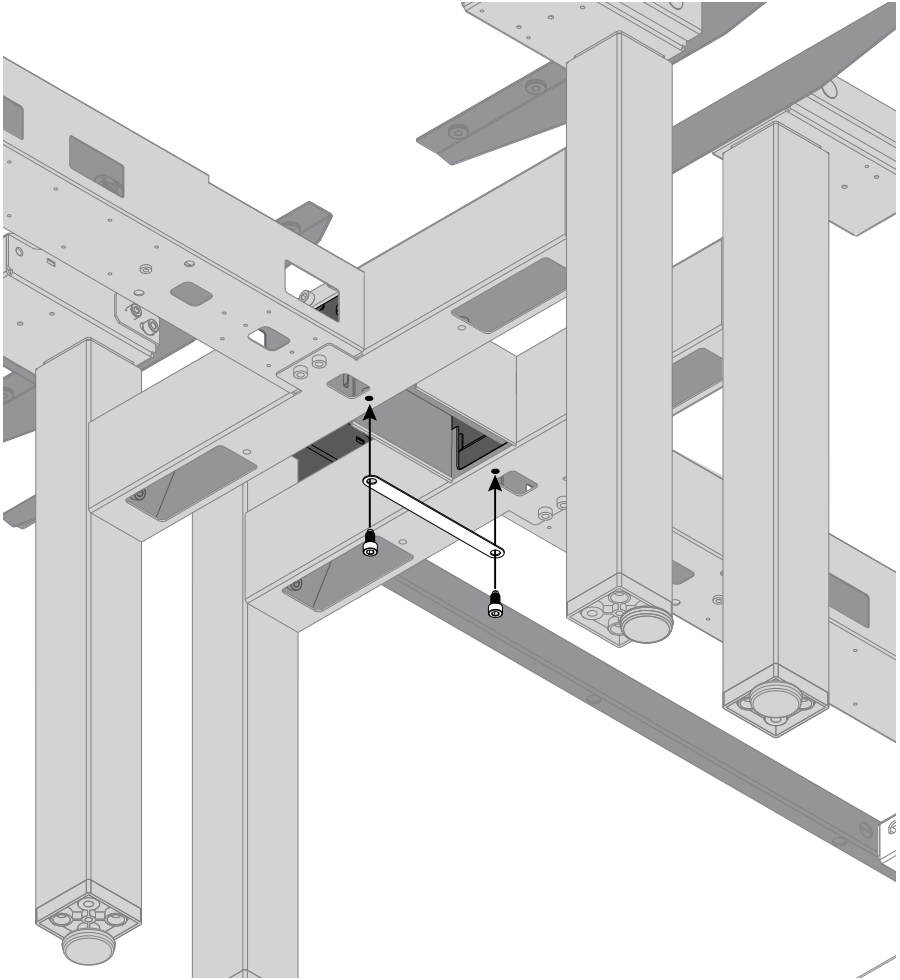

#### 1:1 HARDWARE

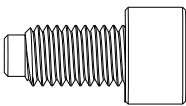

M8 x 16 mm Screw

#### TOOLS



M6 mm Hex L-key

**Step 19:** Connect appropriate cables to data adapters and snap the resulting assembly into the beam.

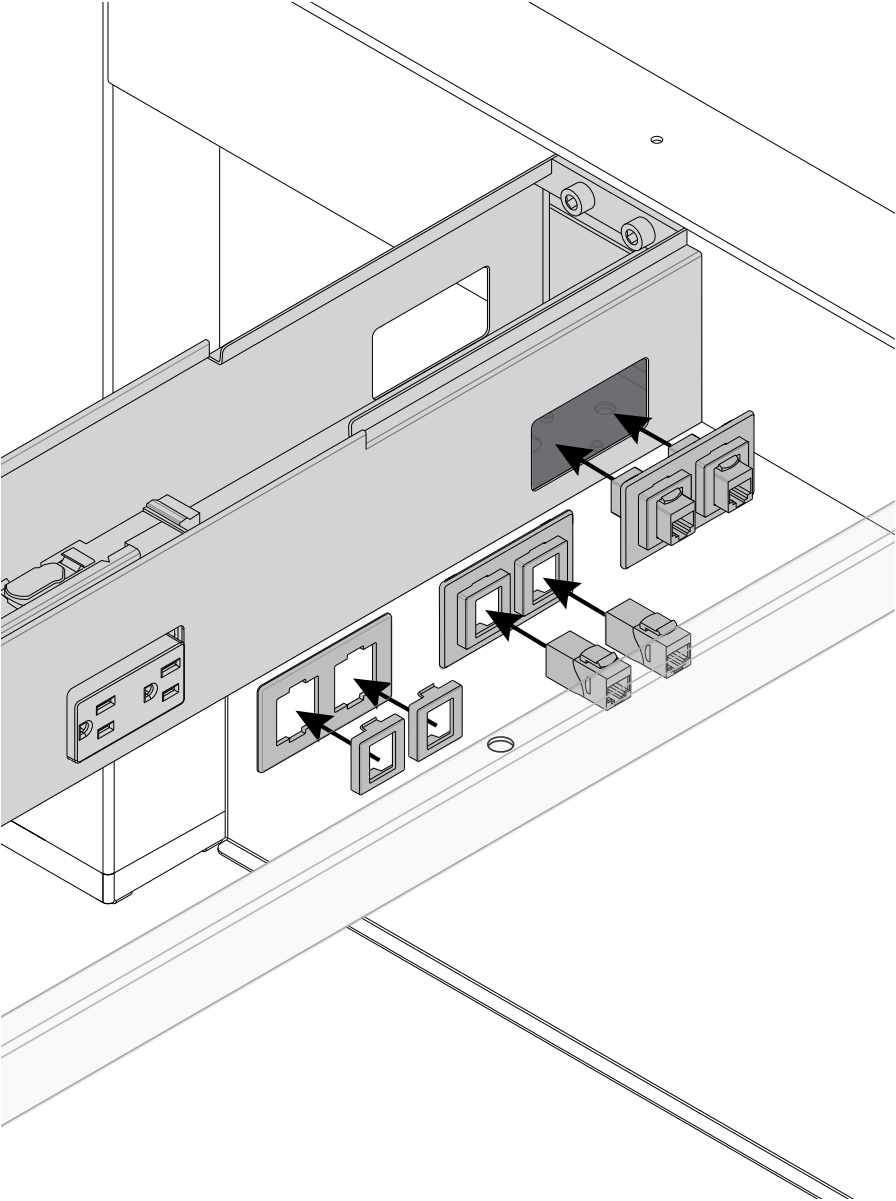

**Step 20:** Snap blank faceplates into the remaining unfilled openings.

---

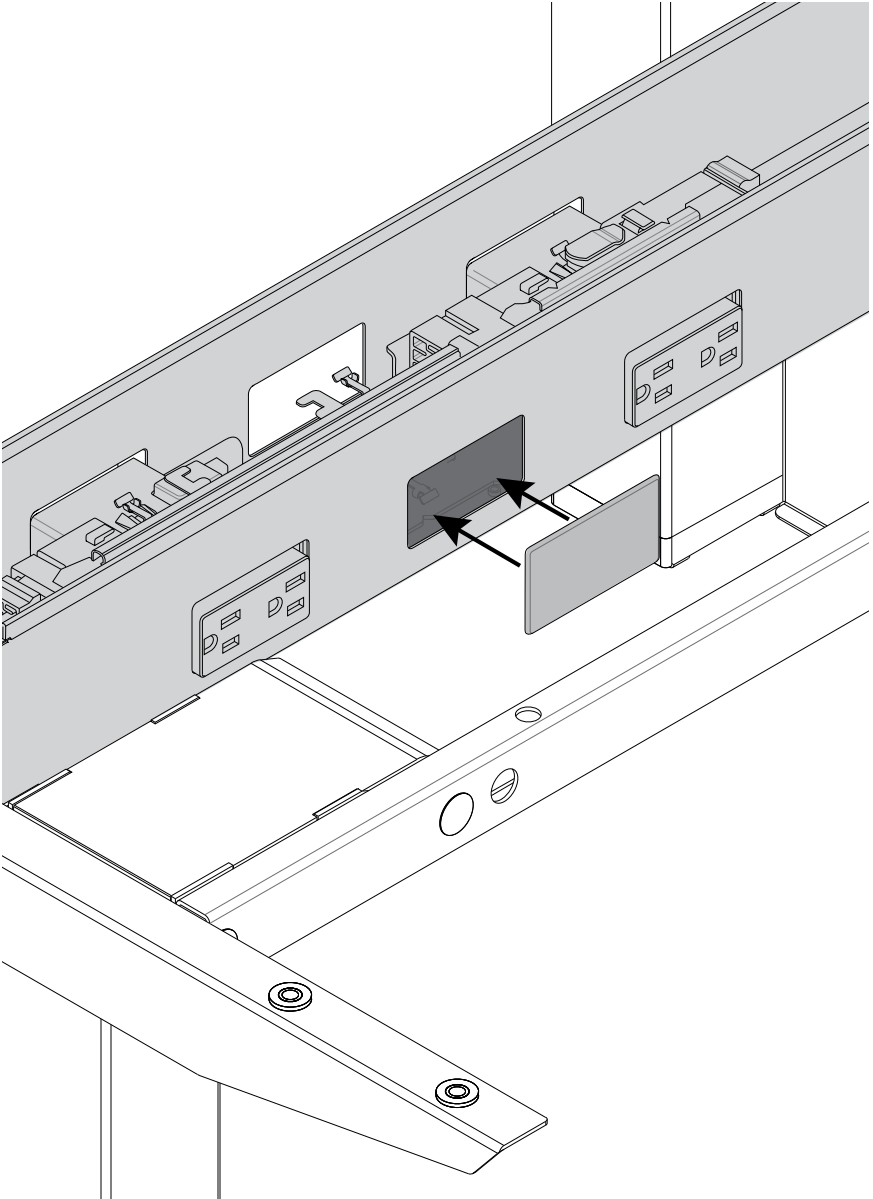



**Step 21:** Install the power lid by pressing it onto the power beam and snapping it into place.

---

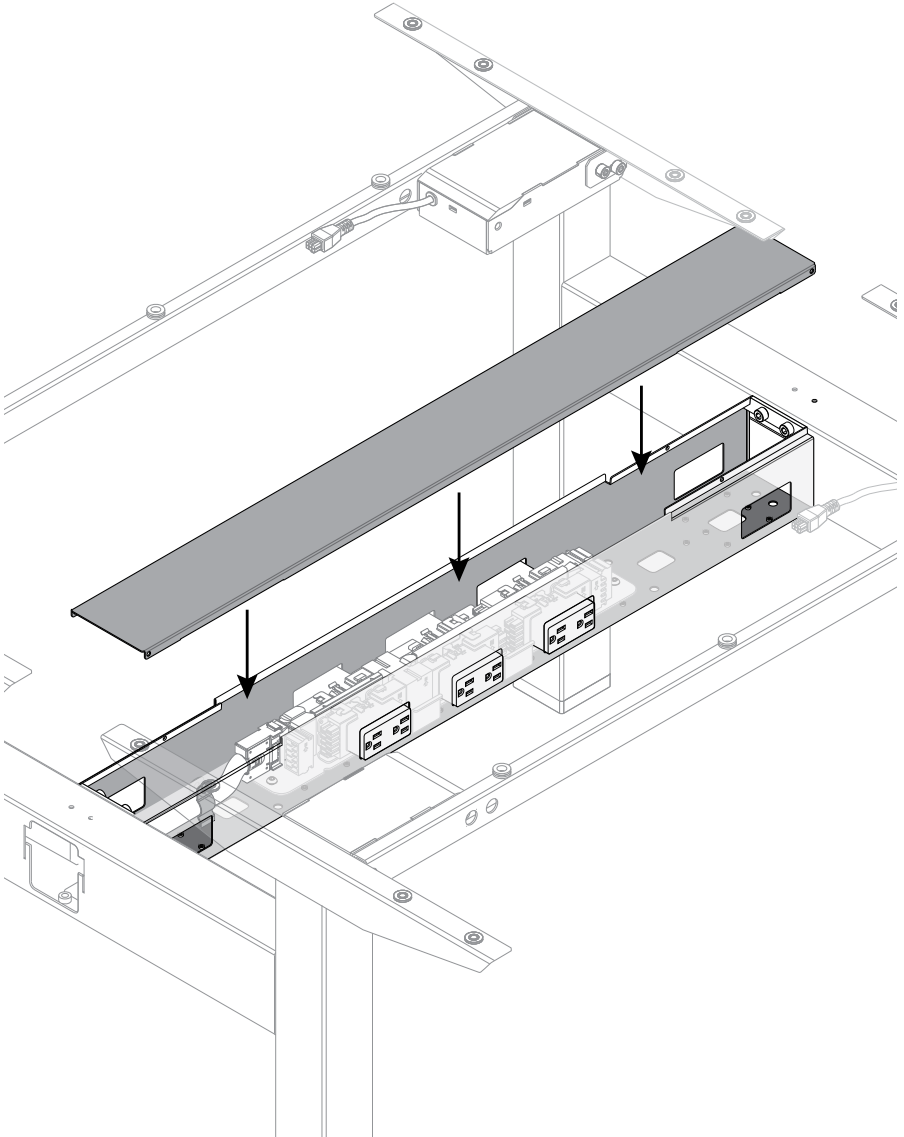

**Step 22:** Cover the holes in the outside of the rails with the bolt caps.

---

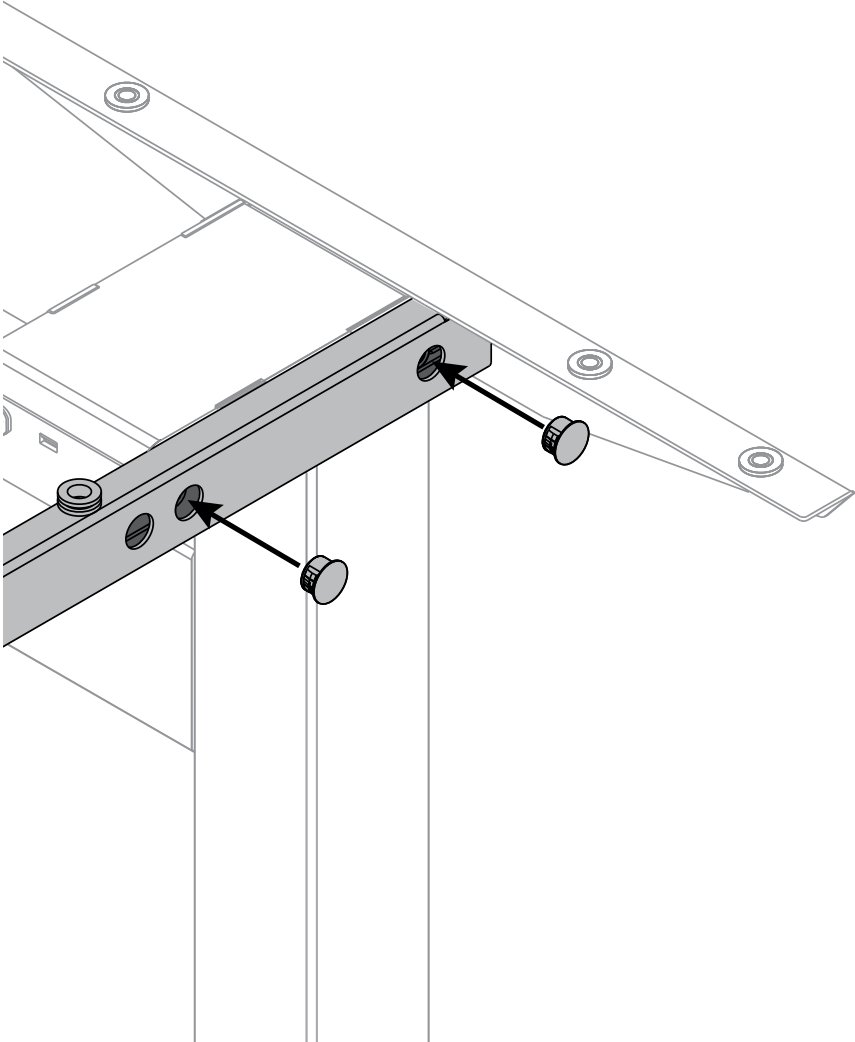

**Step 23:** Place an end cover on each end of the bench.

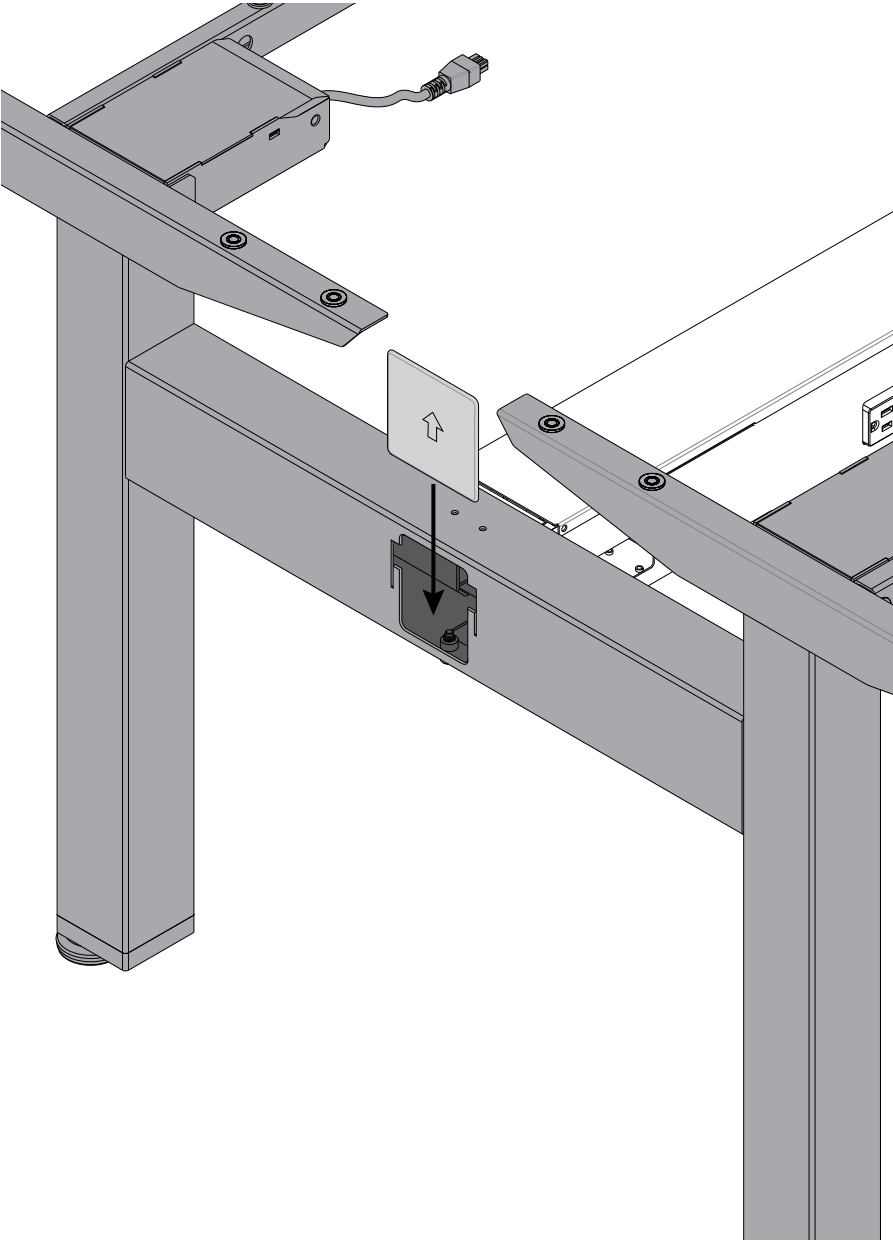

**Step 24:** Attach the tabletop to the bench frame.

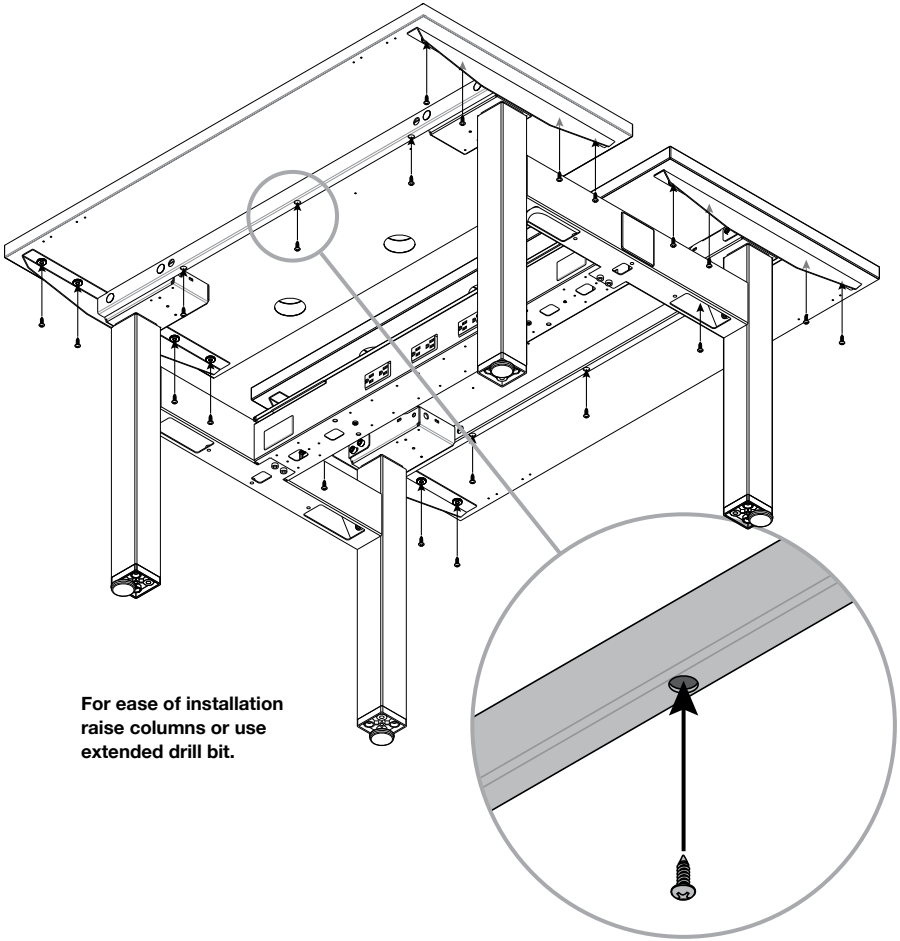

For ease of installation  
raise columns or use  
extended drill bit.

### 1:1 HARDWARE

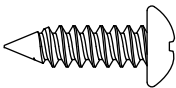

#12 x 3/4" Screw

### TOOLS



#2 Phillips Bit

### Step 25: Attach the control boxes.

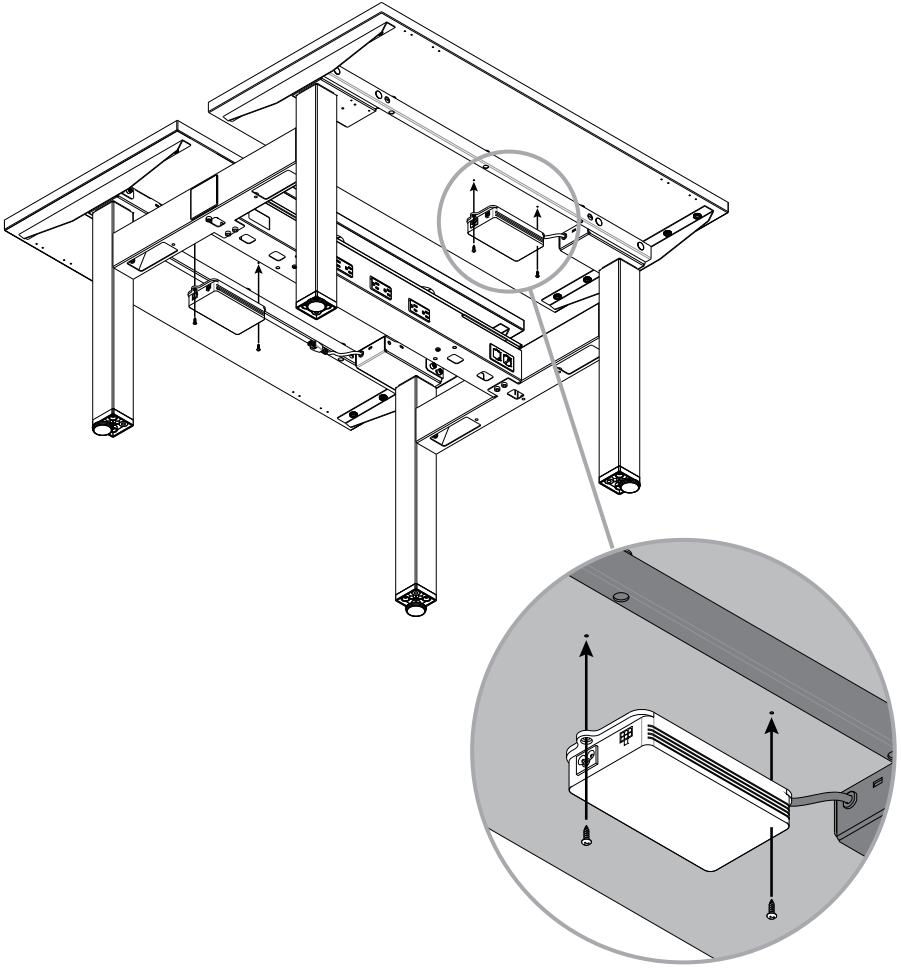

#### 1:1 HARDWARE



M4 x 16 mm Screw

#### TOOLS



#2 Phillips Bit

**Step 26:** Attach the hand control and route the cord through the hole in the frame's rail.

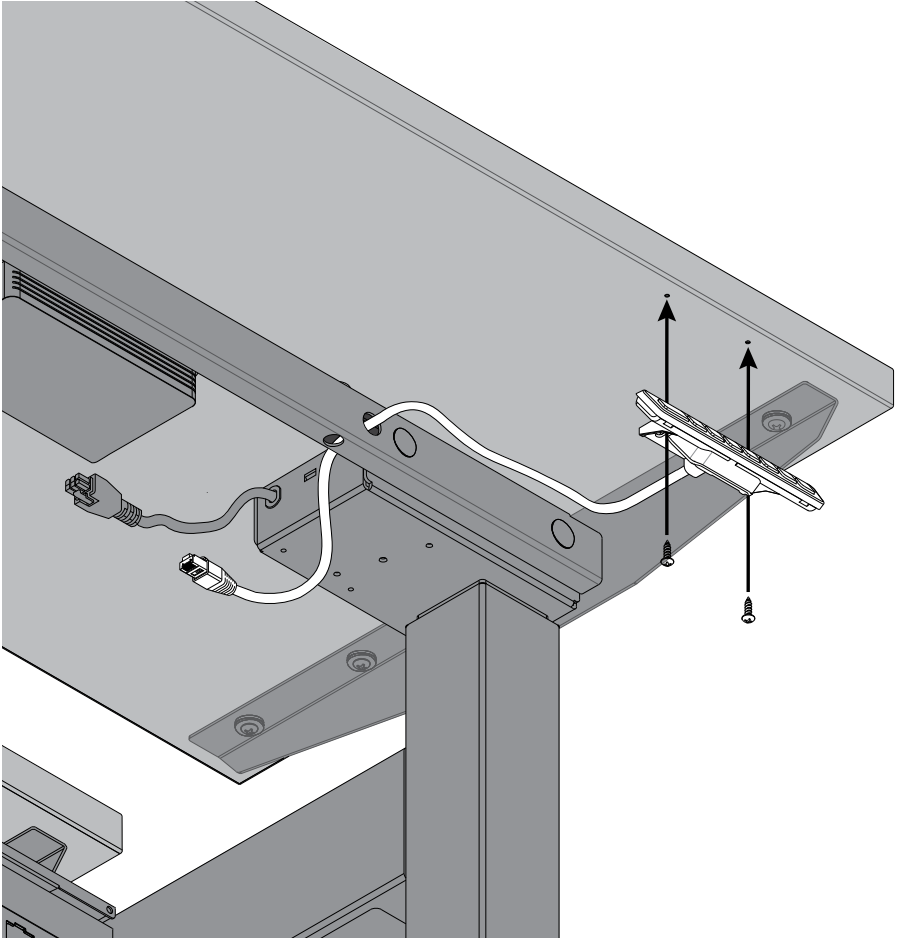
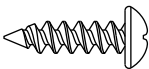
**1:1 HARDWARE**

M4 x 16 mm Screw

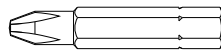
**TOOLS**

#2 Phillips Bit

**Step 27:** Plug the cords into the control box, using the extension cord to span the larger distance between column and control box.

---

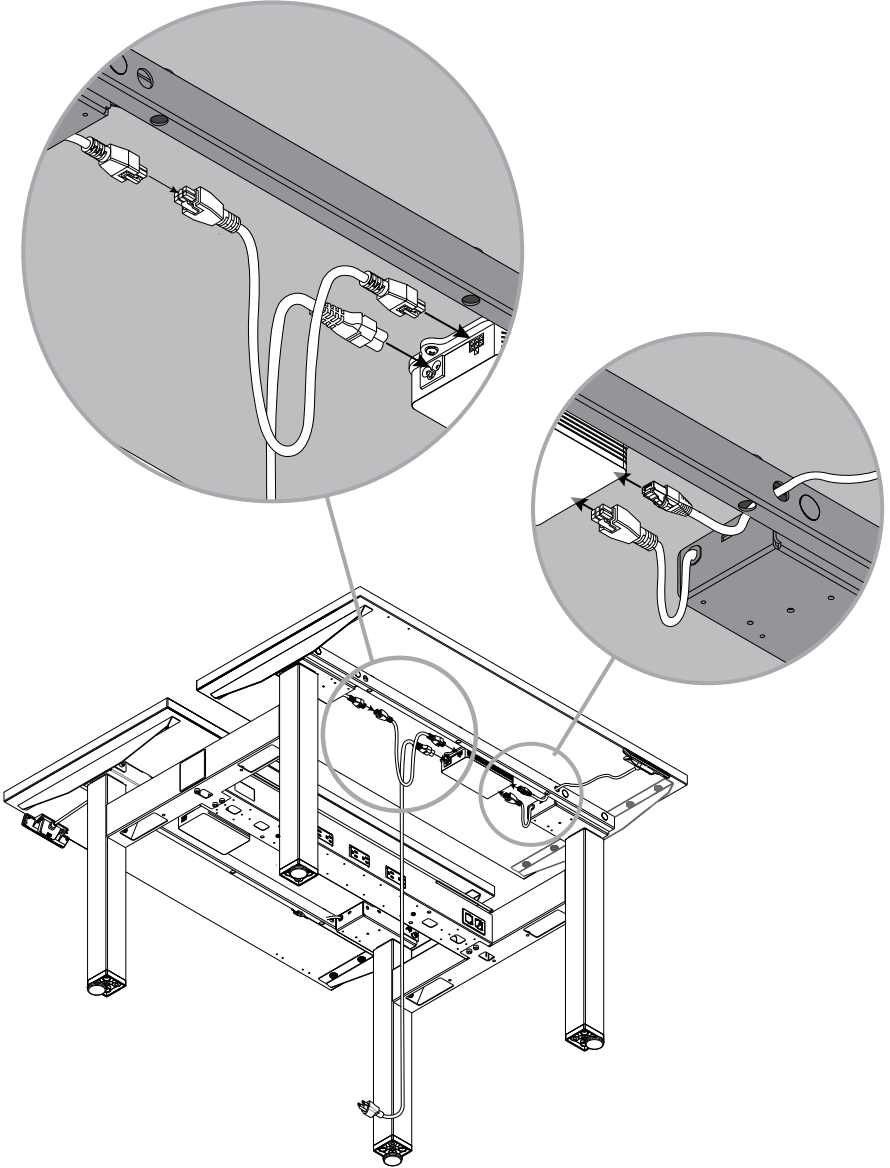

**Step 28:** Attach the wire management; one end to the motor housing and the other to either the wire trough or the power beam.

### NO WIRE TROUGH

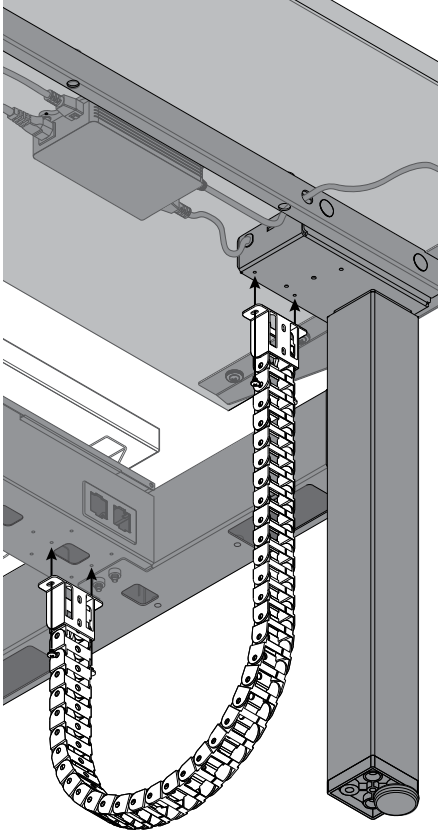

### WIRE TROUGH

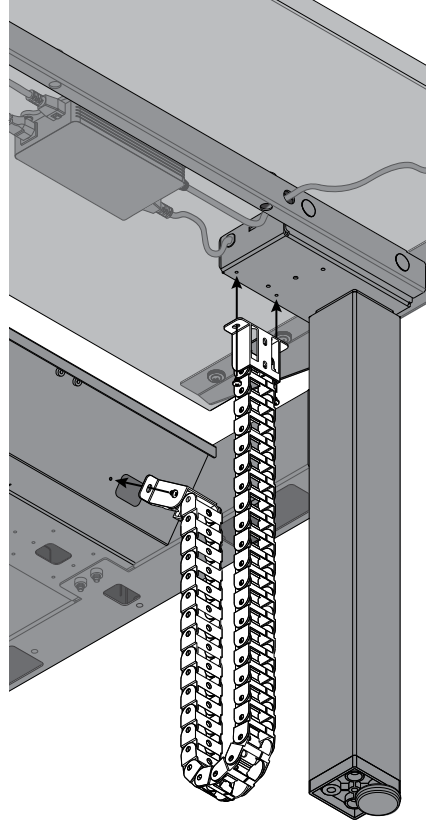

#### 1:1 HARDWARE



3/16" Screw

#### TOOLS



#2 Phillips Bit



## Tabletop Specifications and Mounting Locations

If a tabletop without pilot holes is being installed on the bench, see the information below to determine the correct placement.

### Supported Tabletops

	SitOnIt Seating Tabletops (Recommended)	Non-SitOnIt Seating Tabletops
Core Material	Laminated Particle Board	Laminated Particle Board
Tabletop Width	46" (For 48" Bench) 58" (For 60" Bench) 70" (For 72" Bench)	46" (For 48" Bench) 58" (For 60" Bench) 70" (For 72" Bench)
Tabletop Depth	23" or 29"	23" or 29"
Tabletop Thickness	1.125"	0.78"–1.38"
Weight	5.2–5.7 lb/ft <sup>2</sup>	4–6.8 lb/ft <sup>2</sup>

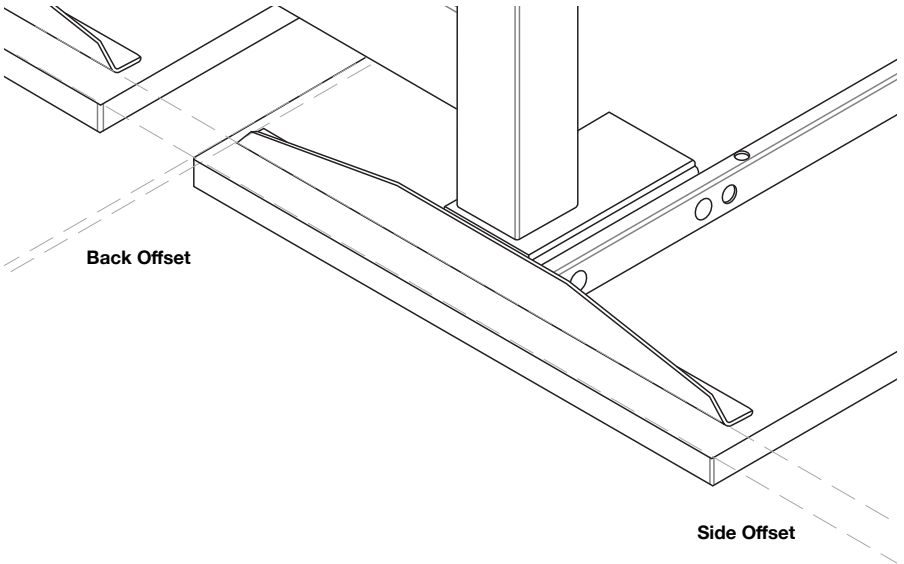

#### Side Offset

Table Width	Offset
46", 58" or 70"	1.3" or 33.1 mm

#### Back Offset

Table Width	Offset
23" or 29"	0.67" or 17.1 mm

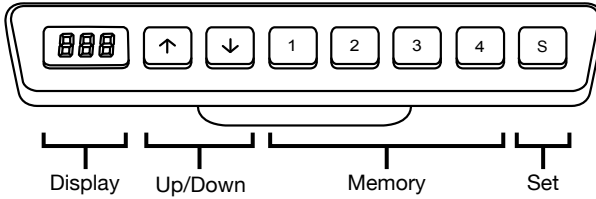

## Initialization

Before the first use, or when the display screen shows "RST".

1. Press the **down** button until the table reaches its lowest position.
2. The table is initialized after it makes a *di* sound and the frame rebounds.

## Reset to Factory Settings

To reset to factory settings, press both **up** and **down** arrows at the same time and hold for ten seconds until you hear a *beep*.

## Temporary (Safety) Lock

**TO LOCK:** press the **up** arrow and the **S** key for five seconds until you see "LOC" on the display.

**TO UNLOCK:** Press the **down** arrow and the **S** key for five seconds until you see "LOC" on the display.

## Anti-Collision

Your height-adjustable desk is also programmed with Anti-Collision technology. When the desk comes into contact with an object it will automatically stop and retract.

## Move Desk Up and Down

Raise the desk by pressing the **up** arrow and lower the desk by pressing the **down** arrow.

## Set a Memory Position

The memory buttons can store up to four preset height positions. To program a button:

1. Press the **S** button and "S-" will begin flashing.
2. Then press any of the buttons numbered one through four to store a preset height.
3. After the height has been set, press one of the buttons to move to the preset height.

## Set the Minimum Height

1. Move the desk to any height below 37 inches
2. Press the **up** and **down** arrows at the same time, and hold for five seconds until you hear a *beep*.

## Set the Maximum Height

1. Move the desk to any height above 38 inches
2. Press the **up** and **down** arrows at the same time, and hold for five seconds until you hear a *beep*.

Error Code	Description	Solution
E1	Faulty Power	Replace power
E2	A-Synchronist Height Over 1 cm	Initialize the table
E4	Handset Error	Unplug and replug the handset in
E6	Faulty Power	Replace power
E7	Faulty Power	Replace power
E7	Sloping Tabletop	Check the tabletop
E11	Motor Defect	Check the motor's wire
E12	Faulty Hand Control	Replace the hand control
E14	Faulty Motor	Replace the motor
E15	Faulty Motor	Replace the motor
E16	Faulty Motor	Replace the motor
E17	Faulty Motor	Replace the motor
E18	Overloaded	Replace the load on the table
E21	Motor Defect	Check the motor's wire
E22	Faulty Hand Control	Replace the hand control
E24	Faulty Motor	Replace the motor
E25	Faulty Motor	Replace the motor
E26	Faulty Motor	Replace the motor
E27	Faulty Motor	Replace the motor
E28	Overloaded	Replace the load on the table
HOT	Overtime Operation	Automatic recovery after 20 minutes

### Specifications

- System rating 20A/120V
- 15 amp duplex receptacle
- Shared neutral wiring systems  
*All shared neutrals use 10 gauge wire, rated at 35 Amps*
- Shared: 8-wire (4-2-2)
- 8-Wire (4-2-2) configuration: Up to 52 receptacles per infeed
- Power infeed options: Flexible and LiquidTight

### UL 183: Manufactured Wiring Systems

- UL listed and CSA certified
- Where Used: full wall panels, tables, underfloor/overhead, other applications
- Reference NEC code 300-22 Section C

### Wiring Configurations

#### 8-Wire 4-2-2 Shared

Lines (12 Ga)	4
Neutrals (10 Ga)	2
Neutrals (12 Ga)	0
Grounds (12 Ga)	2
Utility Circuits	3
Dedicated Circuits	1
Receptacles Per Infeed	52
Receptacles Per Circuit	13

#### 8-Wire 3-3-2 Independent

Lines (12 Ga)	3
Neutrals (10 Ga)	0
Neutrals (12 Ga)	3
Grounds (12 Ga)	2
Utility Circuits	2
Dedicated Circuits	1
Receptacles Per Infeed	39
Receptacles Per Circuit	13

### Compatible VGA Jack

- Byrne 120" VGA Connector

### Compatible Keystone Jacks

- Belden Industrial REVConnect
- Allen Tel Versa Tap Series
- L-com Keystone Jacks
- Levinton Quick Port® System Adapters and Jacks
- Siemon Keystone Connectivity Solutions
- Byrne HDMI Adapter Cable

### Conduit Dimensions

	Flexible	LiquidTight
Size	9/16"	1/2"
Min. External Diameter	0.705"	0.82"
Max. External Diameter	0.735"	0.84"
Minimum Bend Radius	1.5"	3.25"

## 4-2-2 WIRING SCHEMATIC

8-WIRE SHARED NEUTRAL | "3 + 1" — 3 UTILITY CIRCUITS, 1 DEDICATED

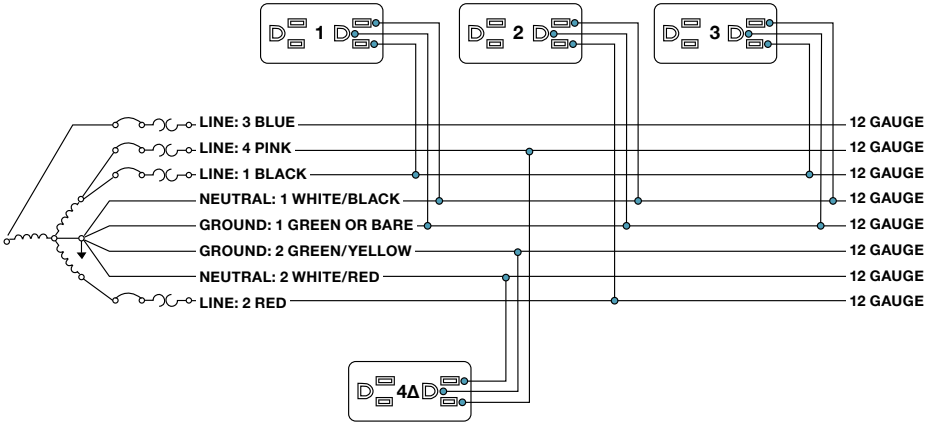

## 120/208V WYE | DELTA CONNECTIONS

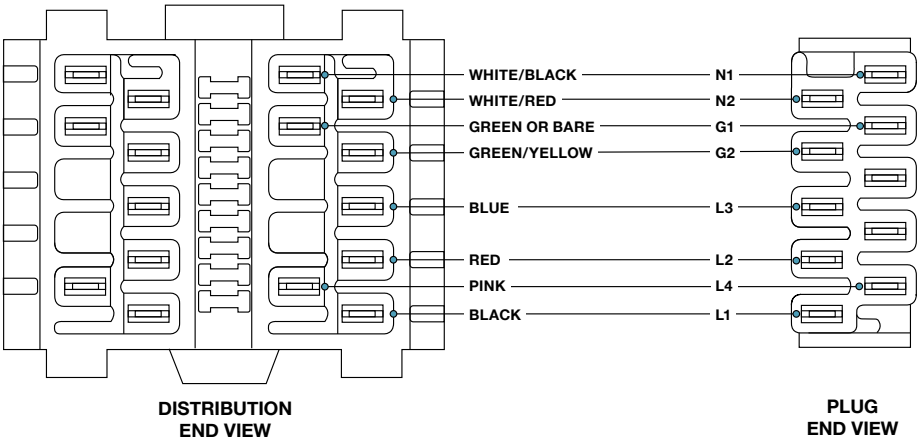

## 4-2-2 WIRING SCHEMATIC

8-WIRE SHARED NEUTRAL | "2 + 2" – 2 UTILITY CIRCUITS, 2 DEDICATED

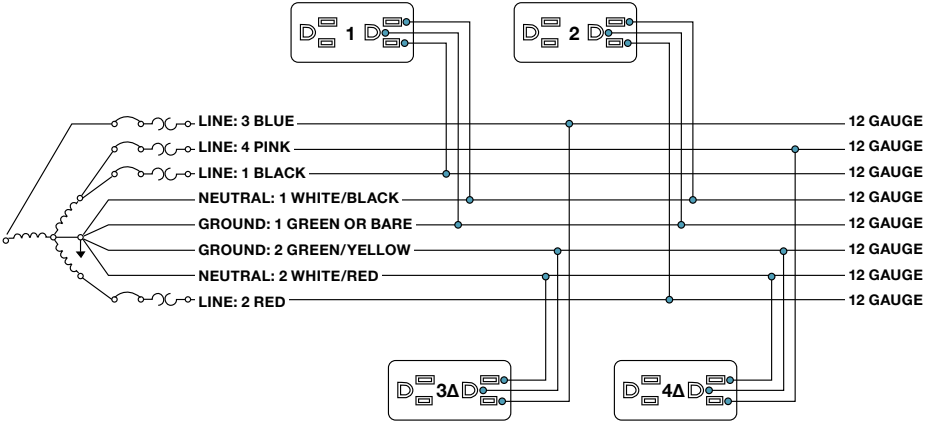

## 120/208V WYE | DELTA CONNECTIONS

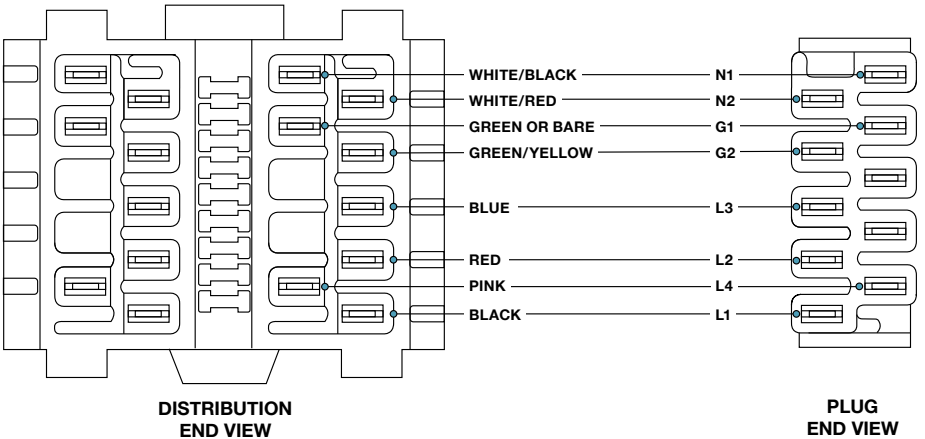

## 3-3-2 WIRING SCHEMATIC 8-WIRE INDEPENDENT NEUTRAL "2 + 1" – 2 UTILITY CIRCUITS, 1 DEDICATED

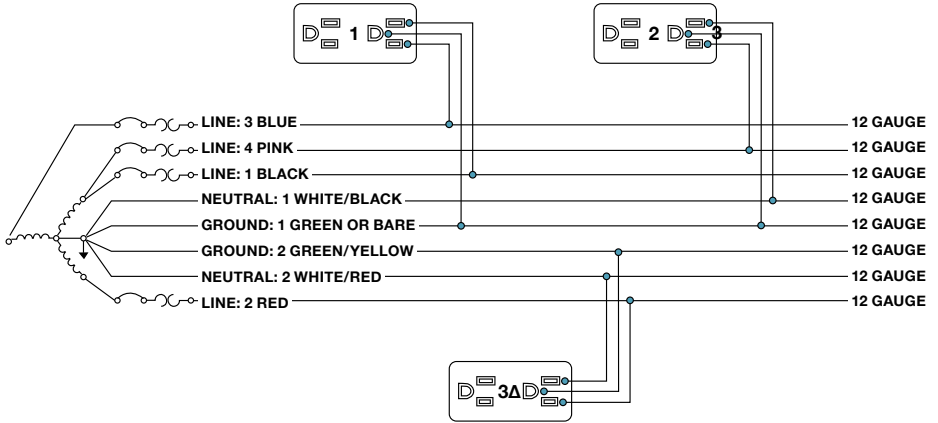

## 120/208V WYE | DELTA CONNECTIONS

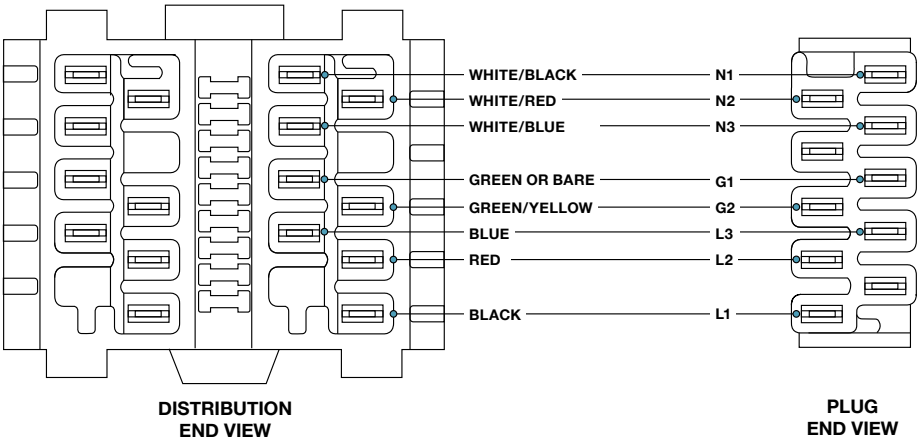

# HiQ

## CENTER SCREENS

### *Elevate your spaces—literally*

HiQ™ is our brand-new height-adjustable total benching solution. This collection lets you take productivity to a higher level with the push of a button, promoting healthier environments through essential ergonomics, connectivity and workspace division. And with a vast lineup of options and add-ons, there's no limit to how you can make it fit anywhere.

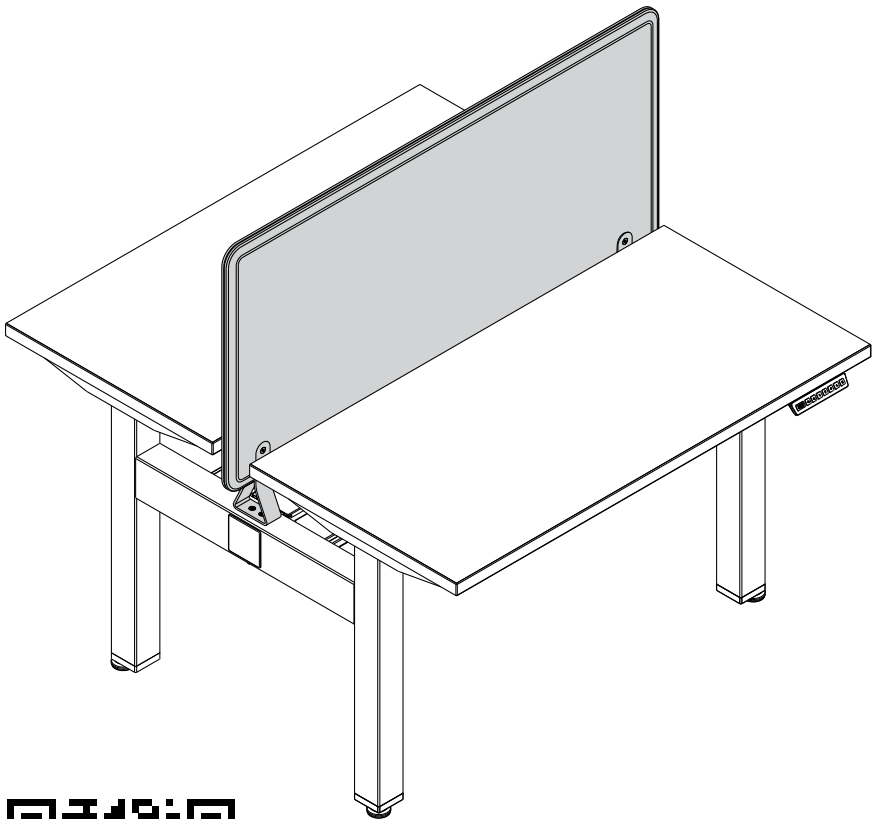

Installation Video



Read the entire instruction manual before you start installation and assembly. If you have any questions regarding any of the instructions or warnings, please contact your local distributor for assistance.

To report any issues with this product, contact our customer experience team at: (866) 764-4111 or [shopcx@sitonit.net](mailto:shopcx@sitonit.net).

## Recommended Tools

---

- 5 mm Hex Key
- T25 Torx Key

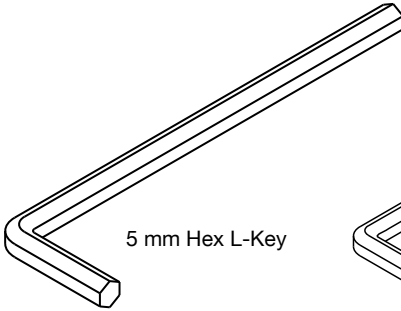

5 mm Hex L-Key

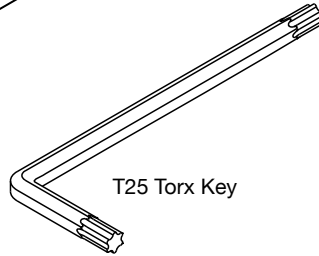

T25 Torx Key

### Parts

- Screen (1)
- Screen Mount (2)
- Alignment Bracket (1)  
(Fabric Screen Only)
- Screen Tool (1) (Fabric Screen Only)
- Spacer (4) (Markerboard Only)
- **Hardware:**
  - M6 × 12 mm Screw (4)
  - #10 × 3/4" Screw (4)
  - 0.8" Binding Barrel (4)

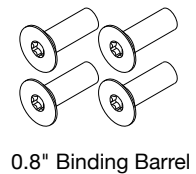
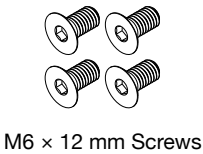
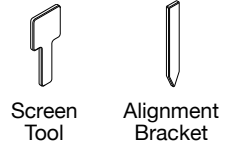
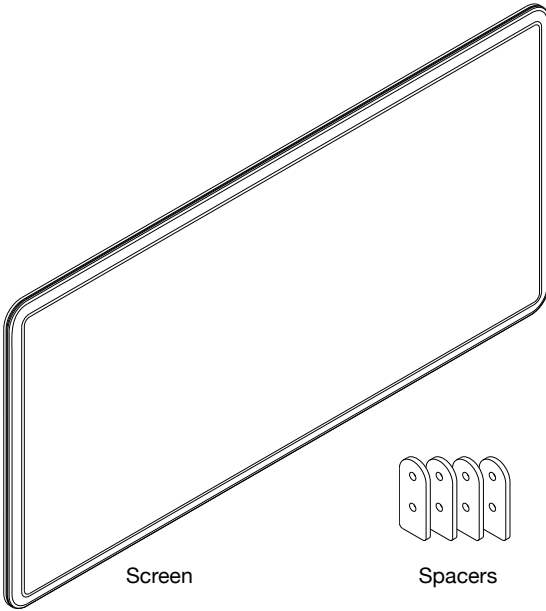

**Step 1:** Raise bench tops to make the beam more easily accessible.

---

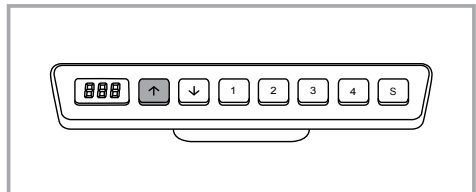
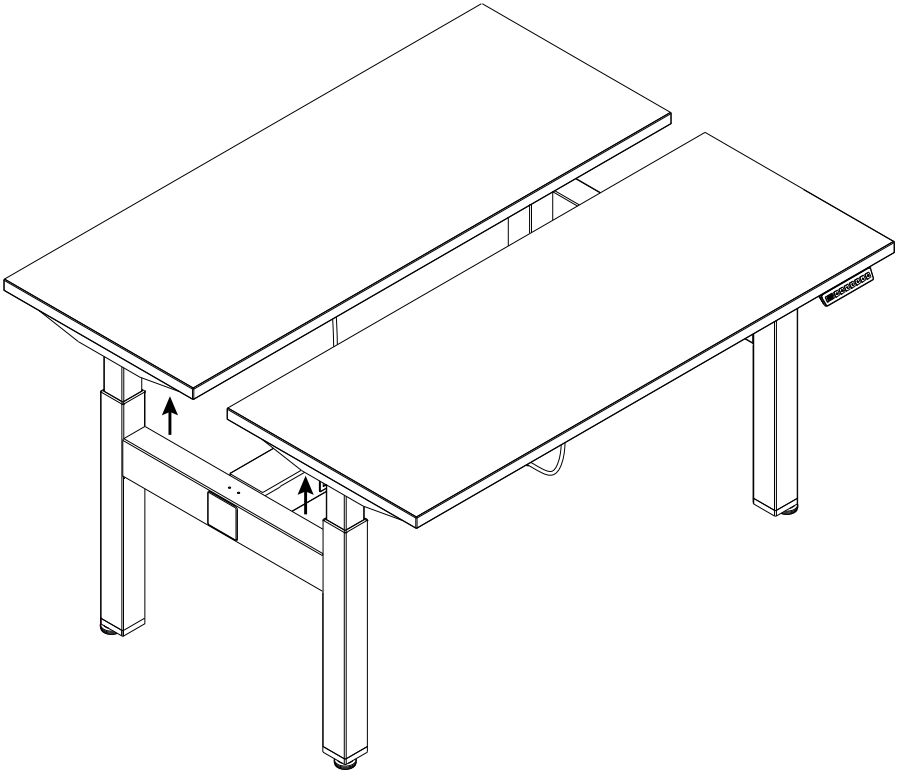

Press the up arrow on the hand control.

**Step 2:** Attach the screen mounts.

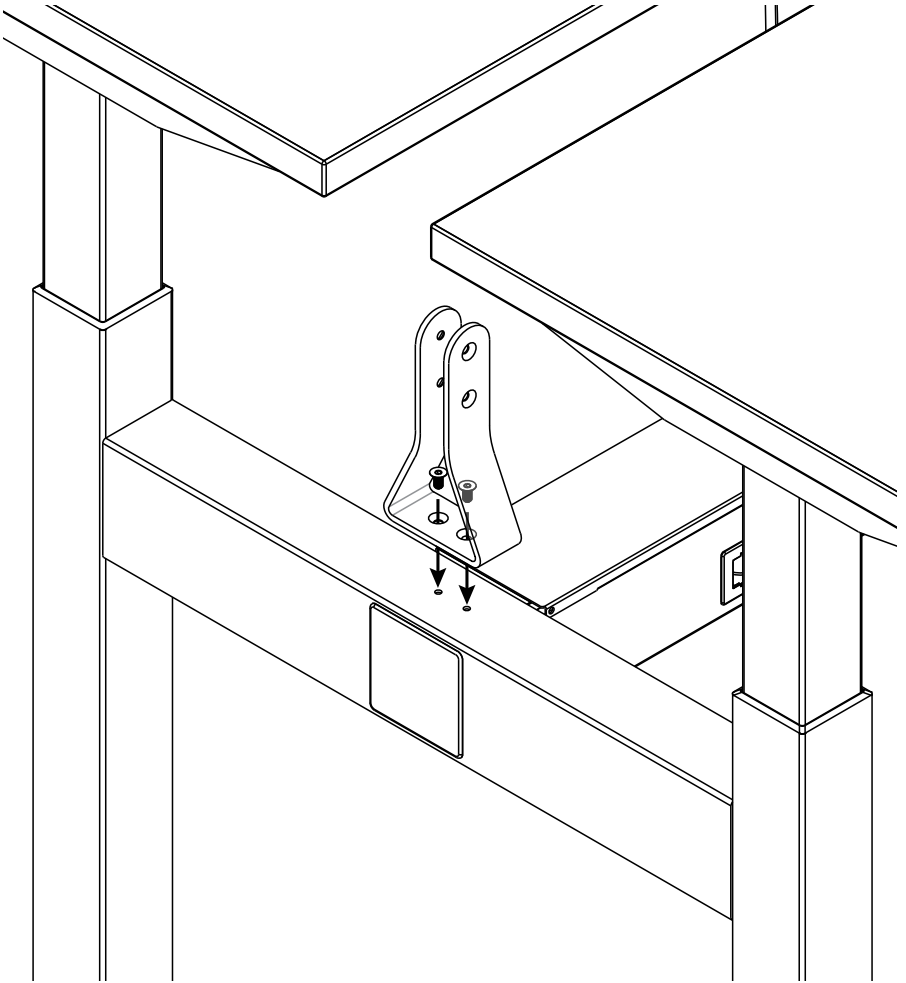

**1:1 HARDWARE**

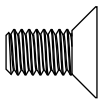

M6 x 12 mm Screw

**TOOLS**



M5 mm Hex L-key

**Step 3:** Insert screen.

---

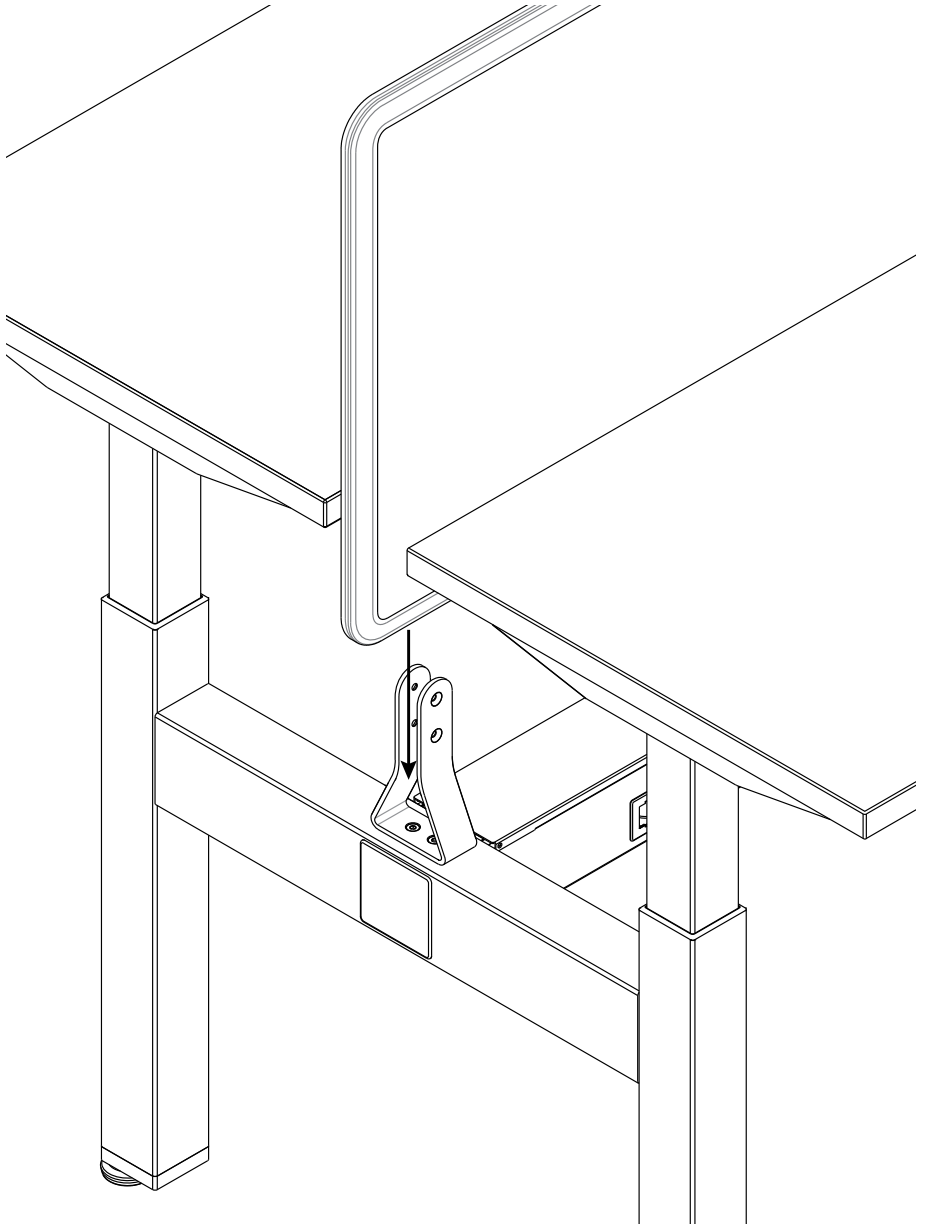

**Step 4 (Markerboard Only):** Insert spacer.

---

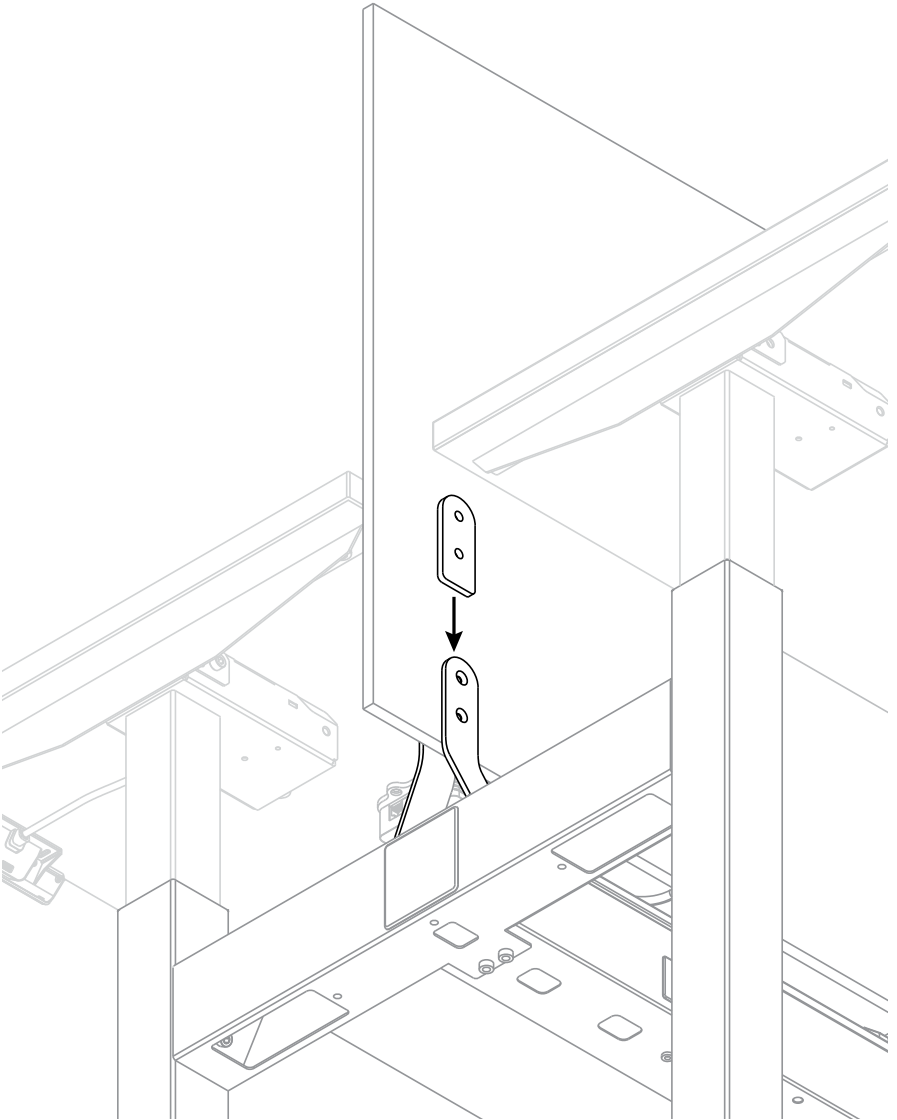

**Step 5:** Insert the binding barrels through the holes in the screen mount and screen. Then, tighten the screws into the binding barrels.

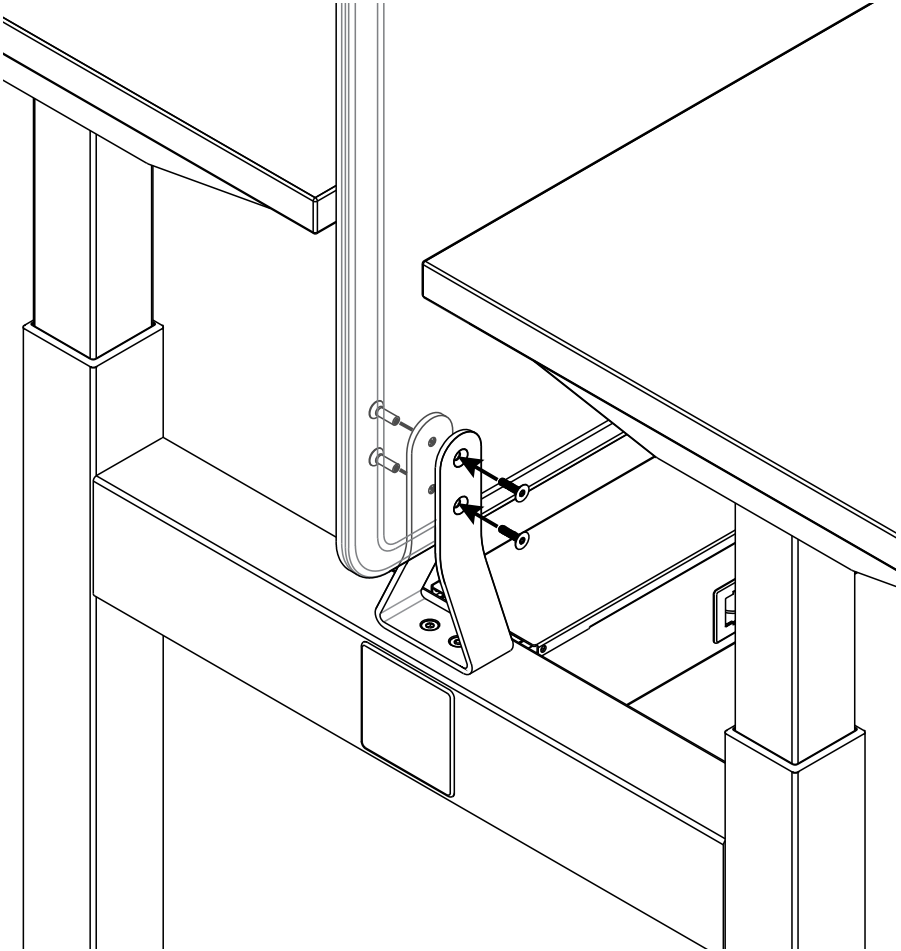

### 1:1 HARDWARE

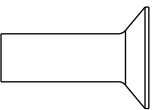

0.8" Binding Barrel

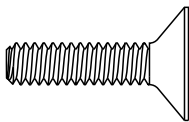

#10 × ¾" Screw

### TOOLS

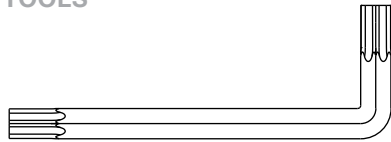

T25 Torx L-key (included)

**Step 6 (Multiple Fabric Screens Only):** If ganging together more than one bench, use the screen tool to press the alignment bracket flush into the gap between the two screens.

---

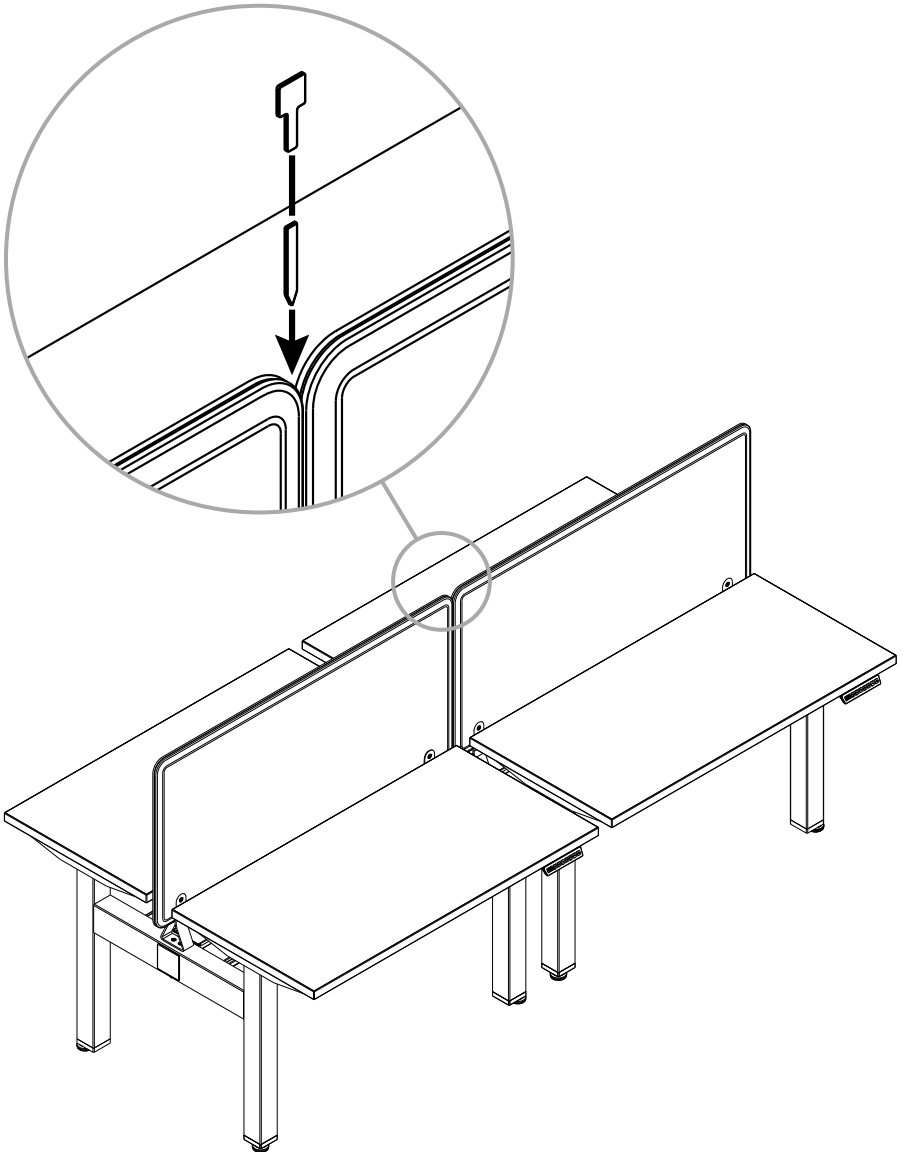



# HiQ

## BOUNDARY SCREEN

### *Elevate your spaces—literally*

HiQ™ is our brand-new height-adjustable total benching solution. This collection lets you take productivity to a higher level with the push of a button, promoting healthier environments through essential ergonomics, connectivity and workspace division. And with a vast lineup of options and add-ons, there's no limit to how you can make it fit anywhere.

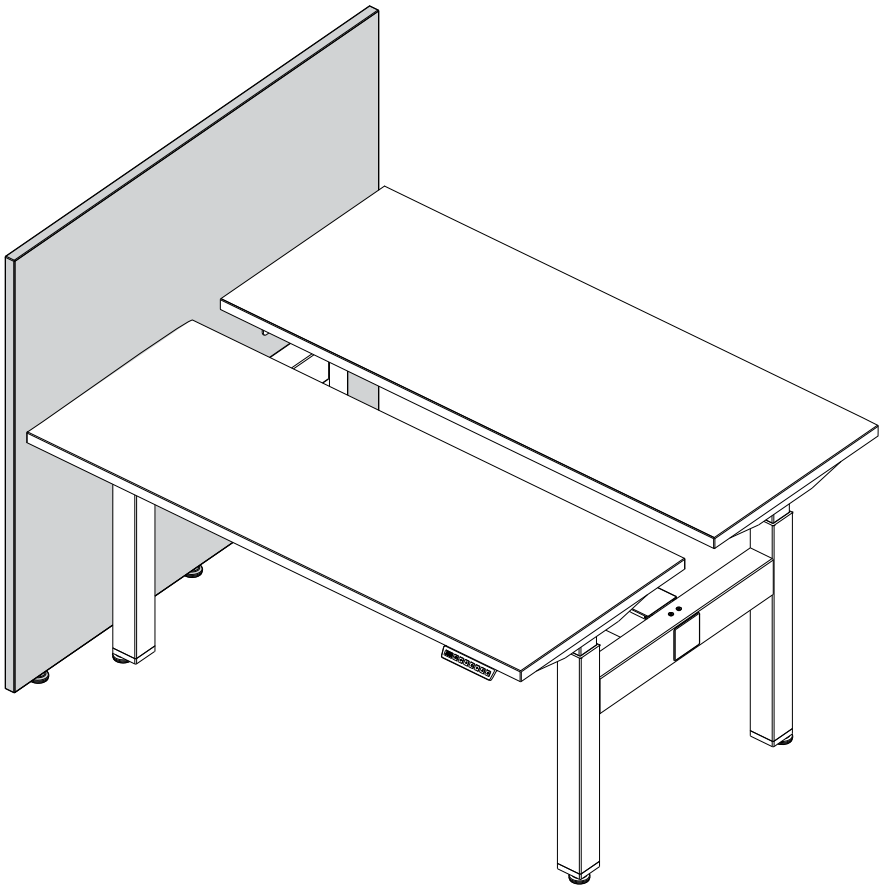

Read the entire instruction manual before you start installation and assembly. If you have any questions regarding any of the instructions or warnings, please contact your local distributor for assistance.

To report any issues with this product, contact our customer experience team at: (866) 764-4111 or [shopcx@sitonit.net](mailto:shopcx@sitonit.net).

### Recommended Tools

---

- Cordless Drill/Driver
- #3 Phillips Bit
- 5 mm Hex Key
- 6 mm Hex Key

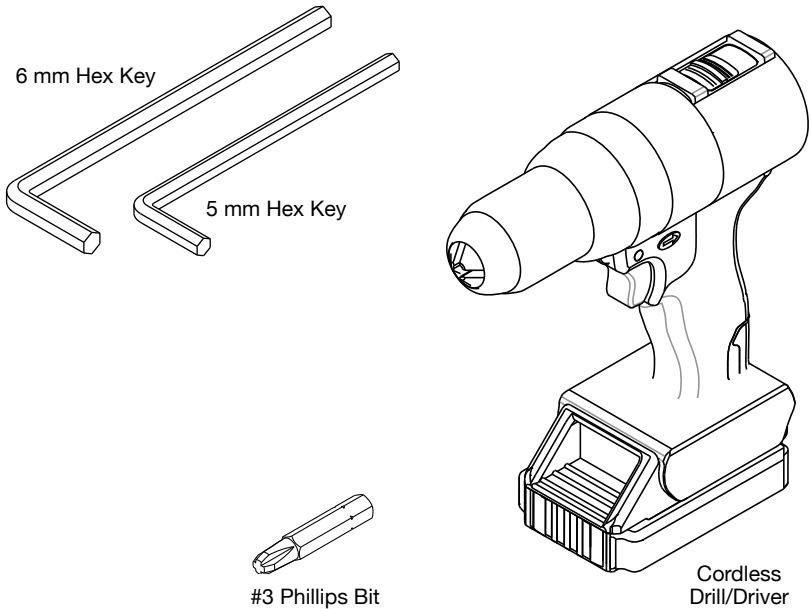

### Parts

- Upper Bracket (2)
- Column Bracket (2)
- Lower Bracket (1)
- Glide (3)

### Hardware

- M8 × 16 mm Screw (3)
- M6 × 12 mm Screw (8)
- #12 × 3/4" Screw (14)

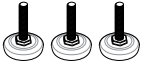

Glides

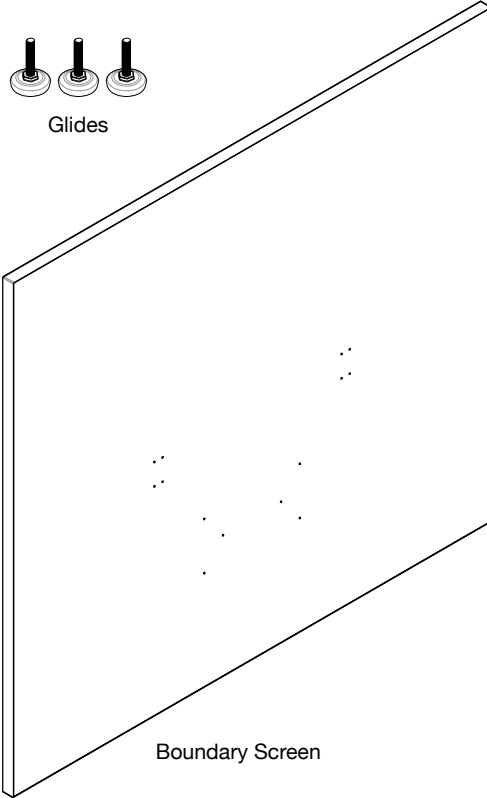

Boundary Screen

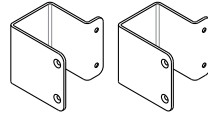

Column Brackets

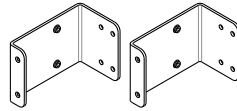

Upper Brackets

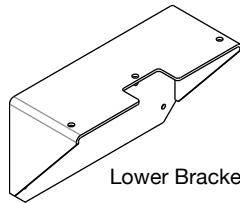

Lower Bracket

### HARDWARE



M8 × 16 mm Screws

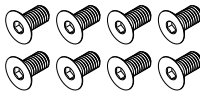

M6 × 12 mm Screws

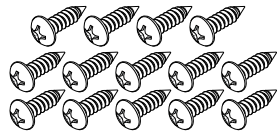

#12 × 3/4" Screws

**Step 1:** Slide the column bracket onto the column.

Repeat on the other column.

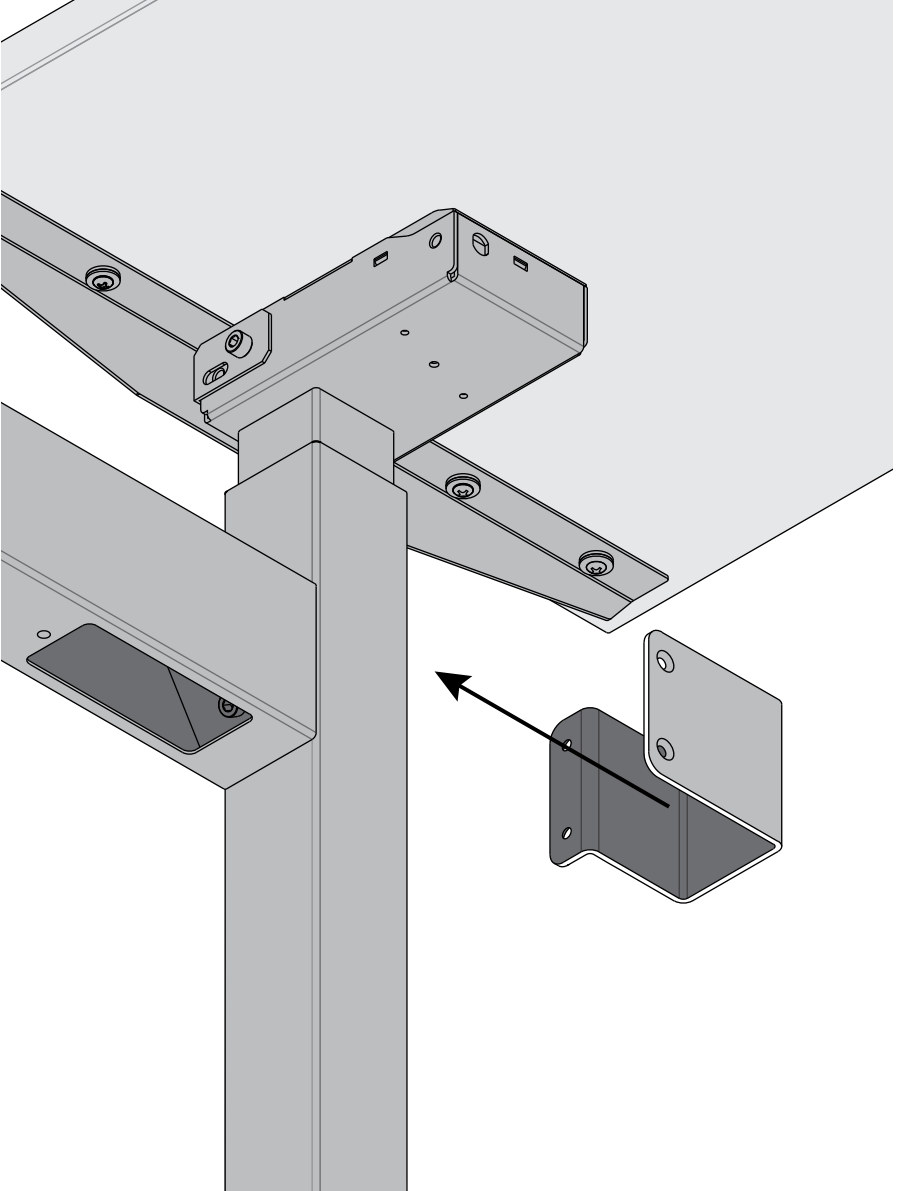

**Step 2:** Nest the upper bracket against the column bracket.

Repeat on the other column.

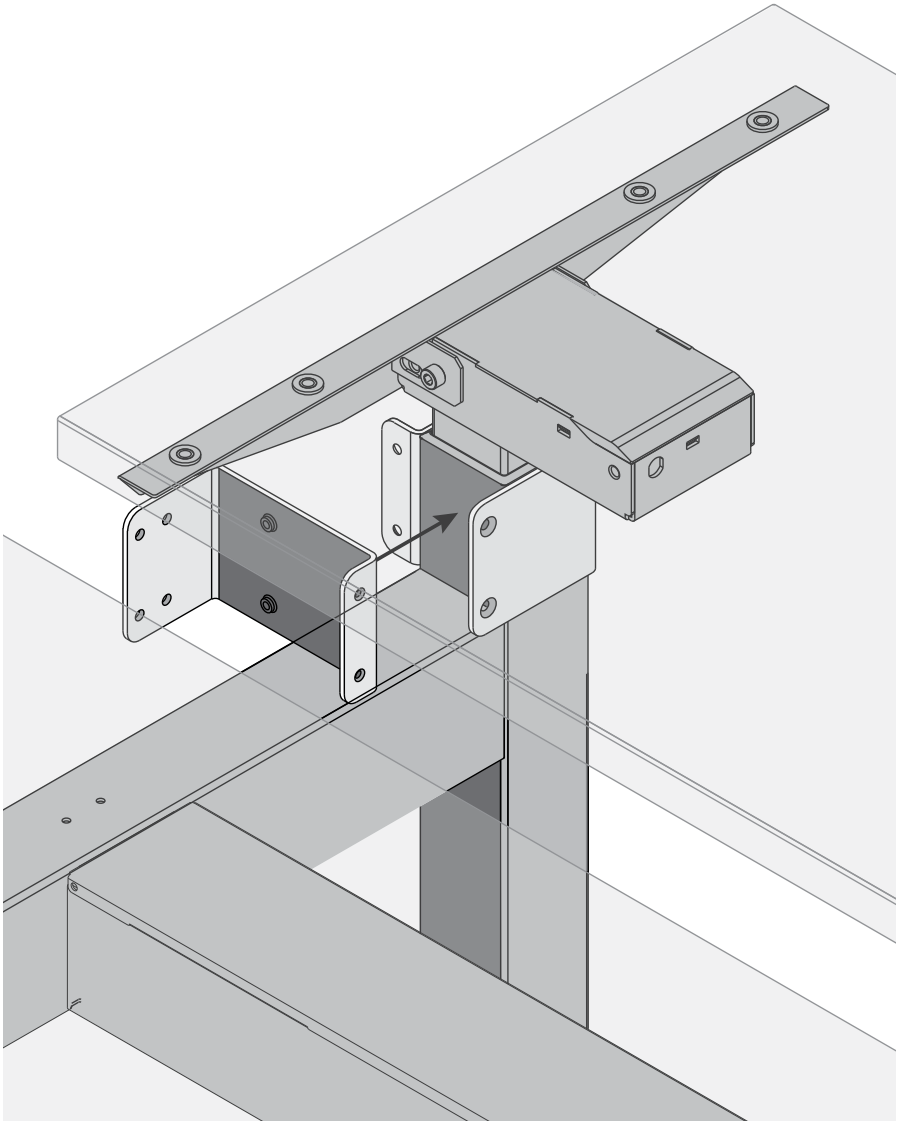

**Step 3:** Connect the brackets where they overlap, using two screws on the inside.

Repeat on the other column.

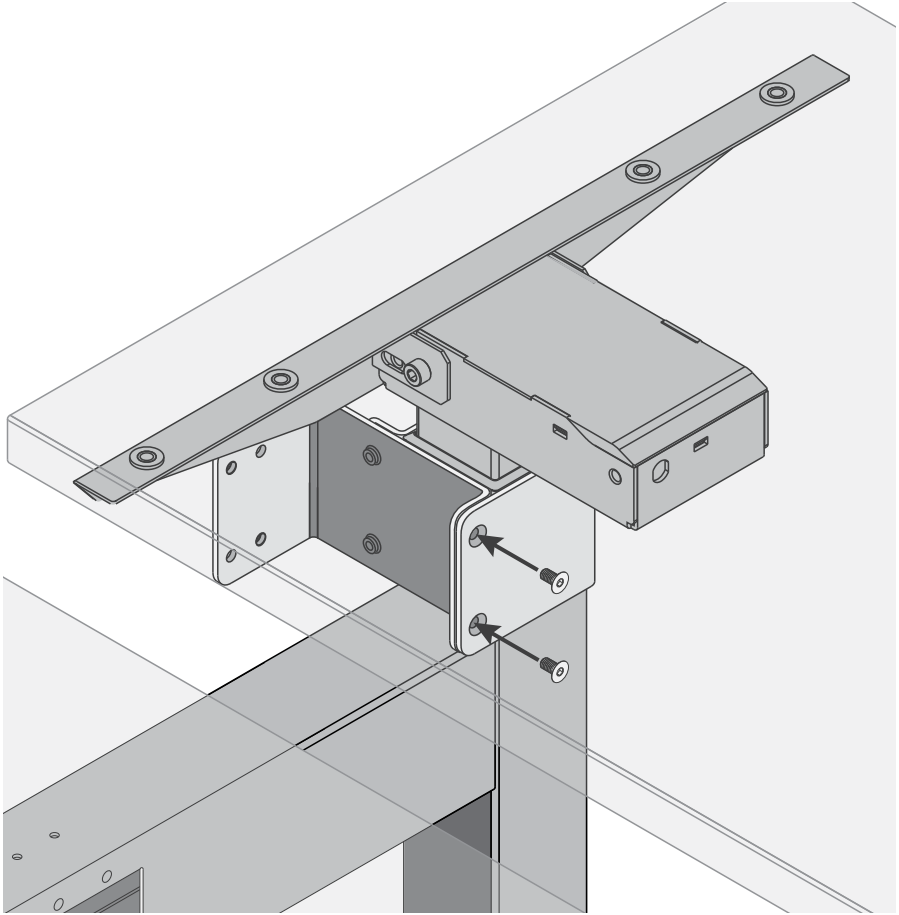

#### 1:1 HARDWARE



M6 x 12 mm Screw

#### TOOLS



M5 mm Hex L-key

**Step 4:** Connect the brackets where they overlap, using two more screws on the outside.

Repeat on the other column.

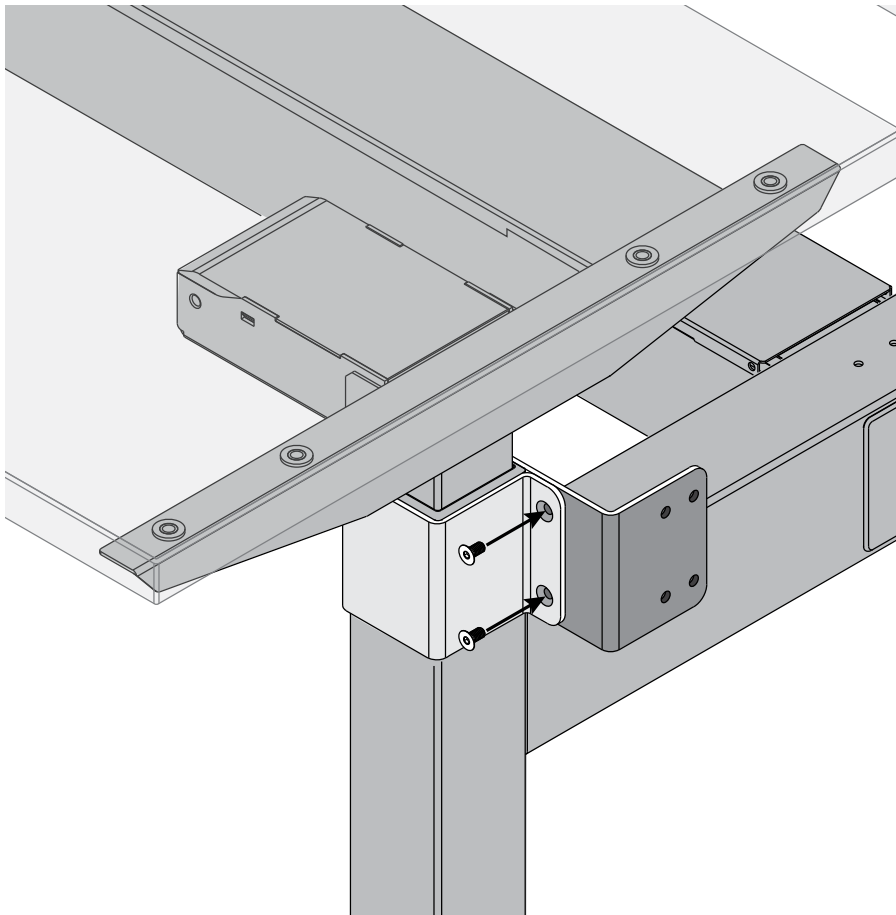

#### 1:1 HARDWARE



M6 × 12 mm Screw

#### TOOLS



M5 mm Hex L-key

**Step 5:** Attach the lower bracket to the crossbeam.

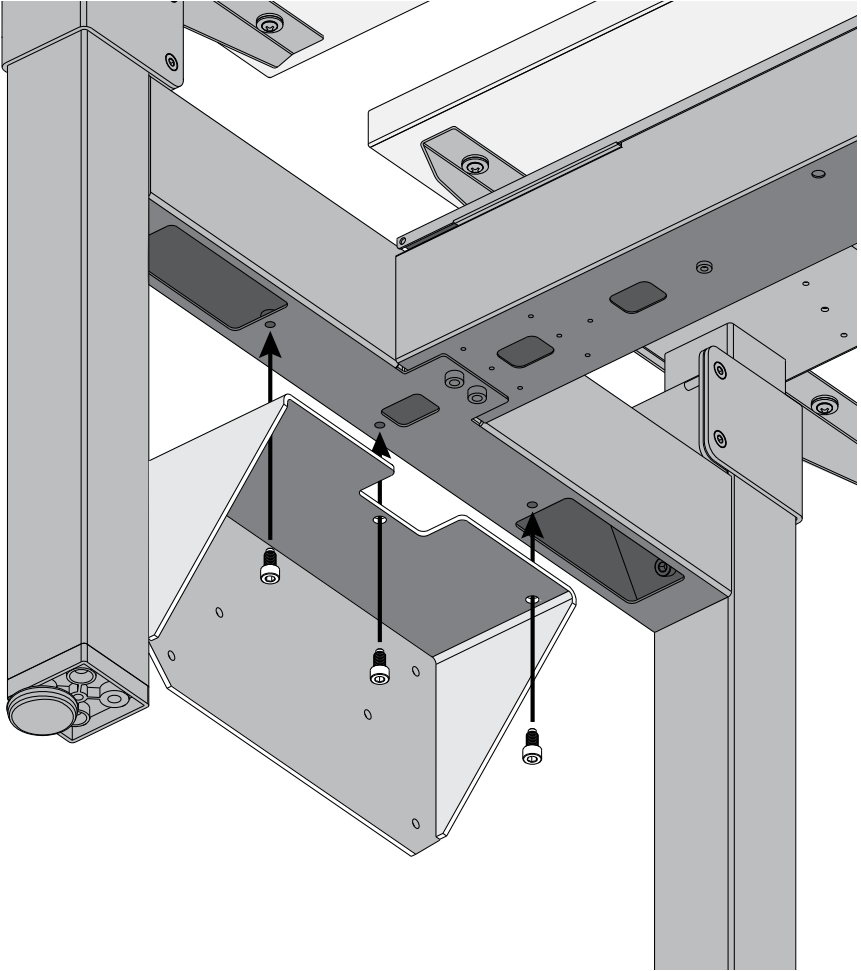

### 1:1 HARDWARE

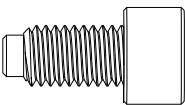

M8 × 16 mm Screw

### TOOLS



M6 mm Hex L-key



**Step 6:** Screw the glides into the boundary screen's pre-installed T-nuts. Unscrew the glides as needed to level.

---

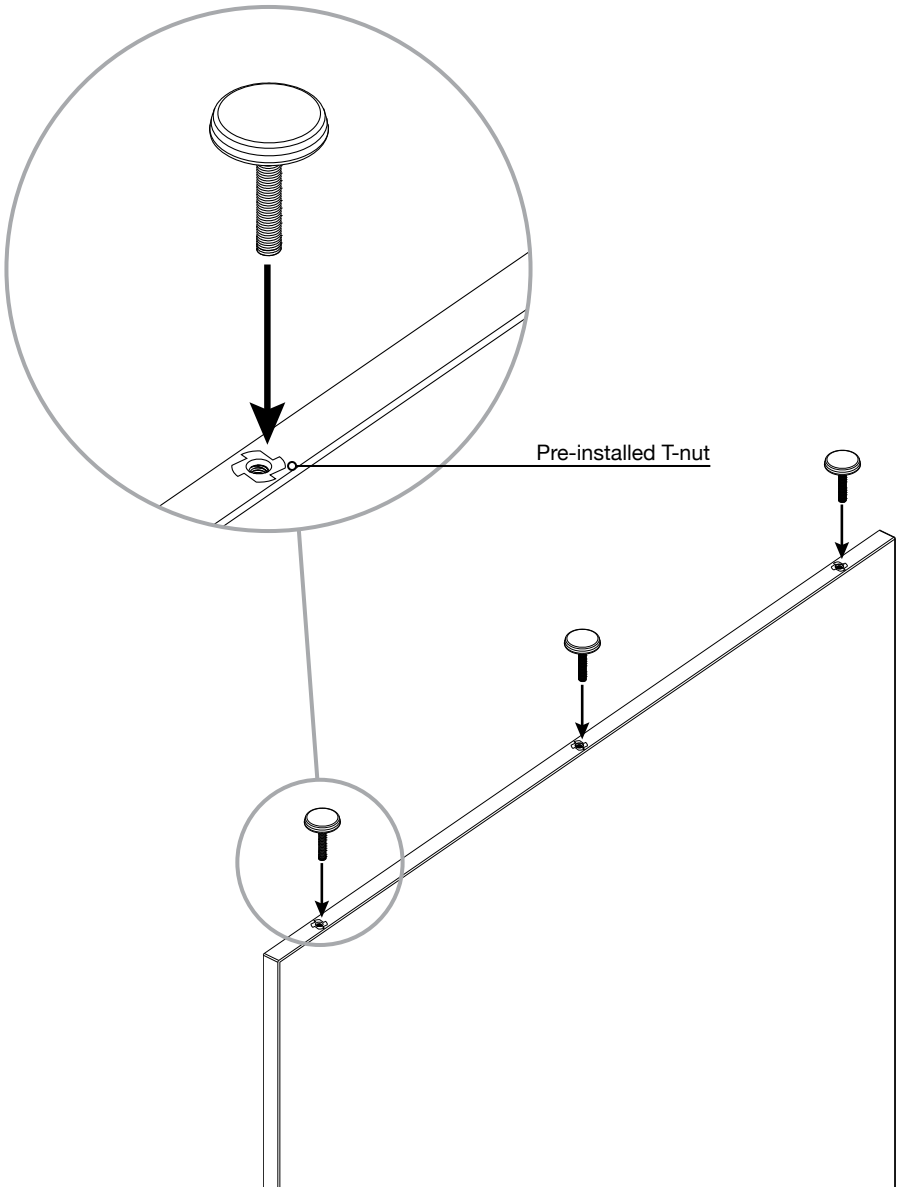

**Step 7:** Attach the boundary screen to the lower bracket.

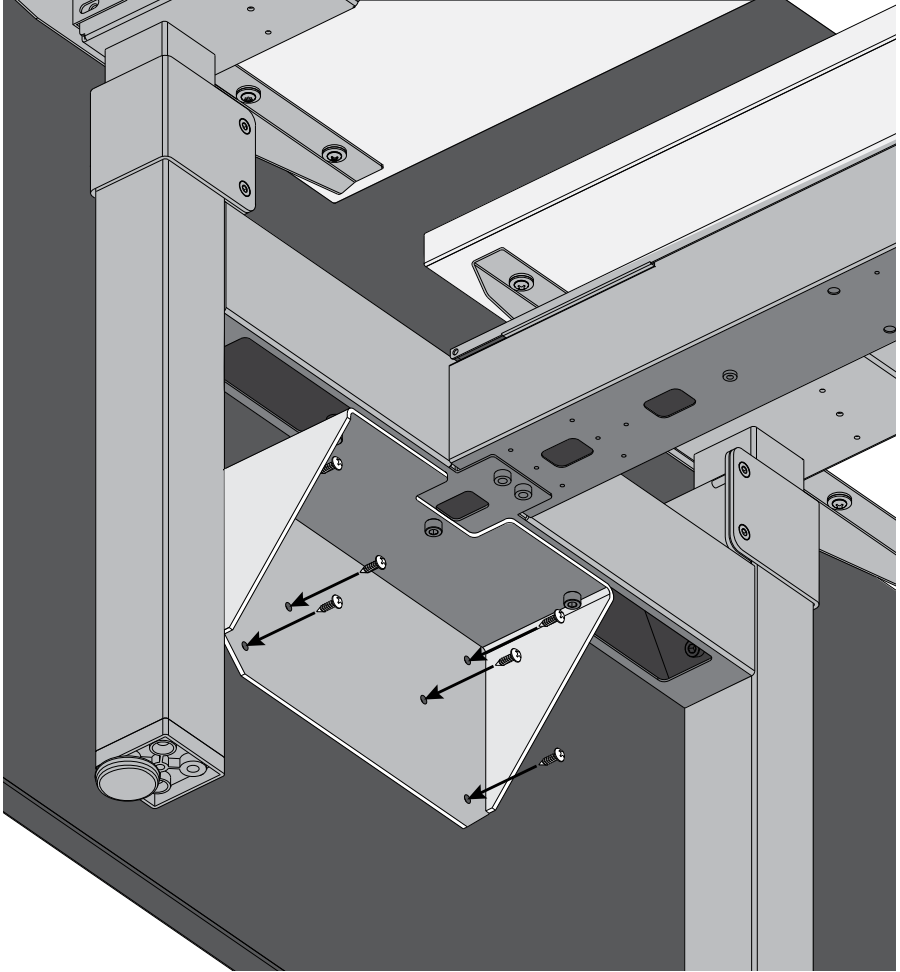

**1:1 HARDWARE**

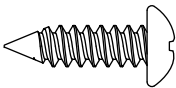

#12 × ¾" Screw

**TOOLS**

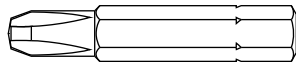

#3 Phillips Bit

**Step 7:** Attach the boundary screen to the upper bracket.

Repeat on the other column.

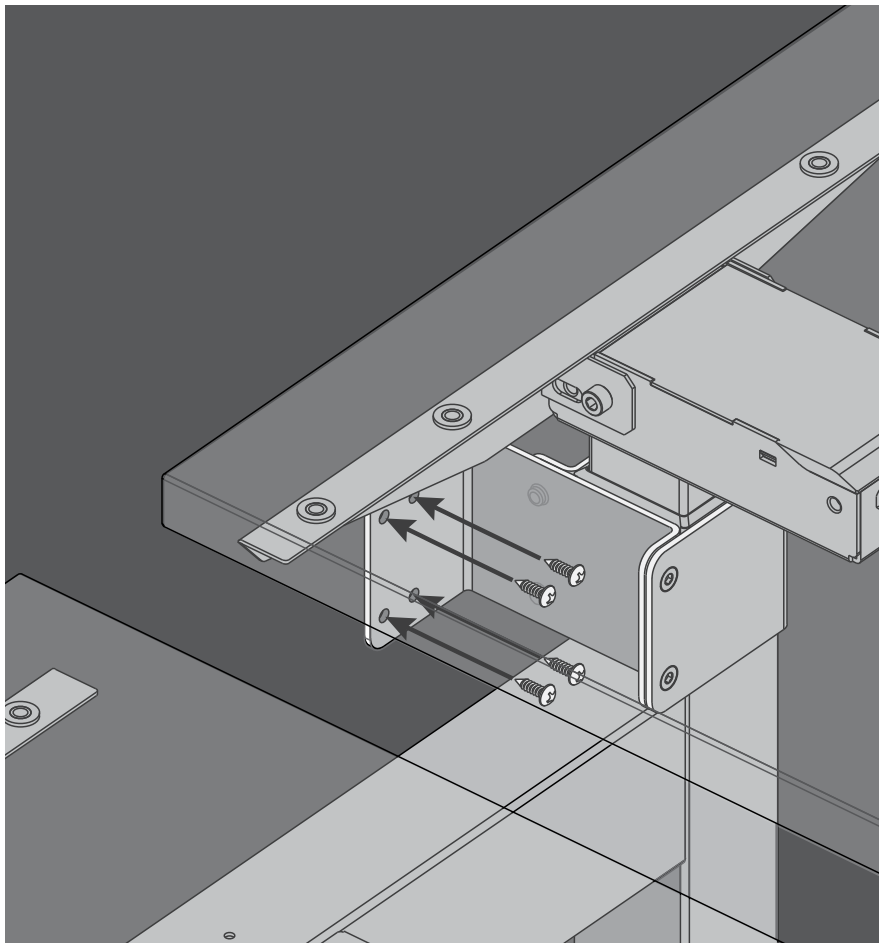

**1:1 HARDWARE**

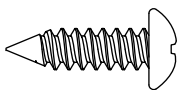

#12 × ¾" Screw

**TOOLS**

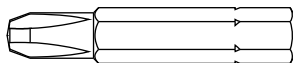

#3 Phillips Bit